

# Du musée à l'hôpital : les violons du MIM au scanner

## Van het museum naar het ziekenhuis: De violen van het MIM door de scanner

Mirte Maes

Anne-Emmanuelle  
Ceulemans

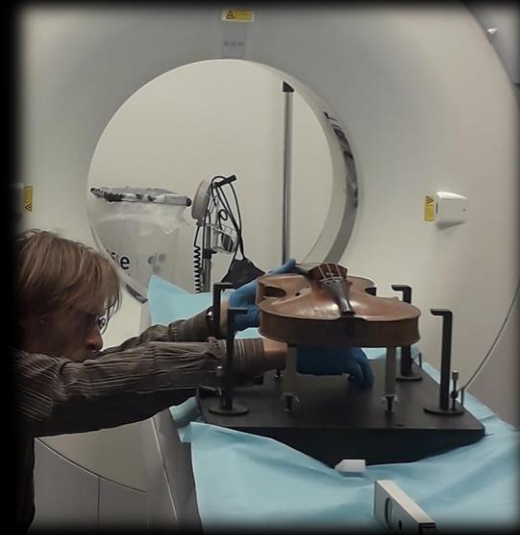

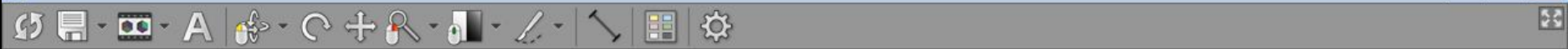

VR

I



L

R



WL: -538 WW: 409

S

L-R: 21.5° S-I: 14.1° Roll: -170.5°

MPR

MPR

2778

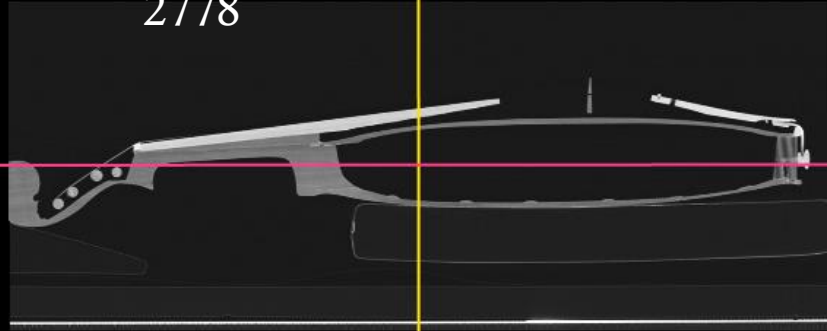

WL: -400 WW: 1500

MPR

L

R

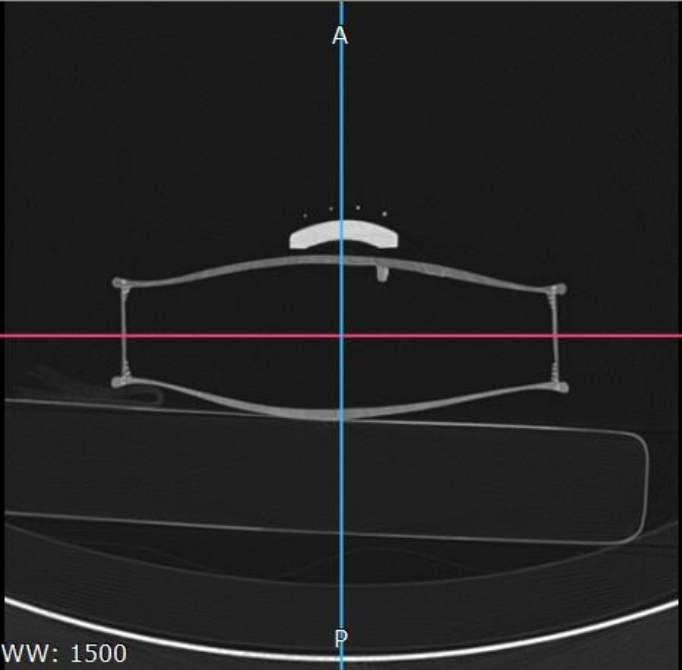

WL: -400 WW: 1500

WL: -400 WW: 1500

S

Pas de parallaxe



## Scanners industriels

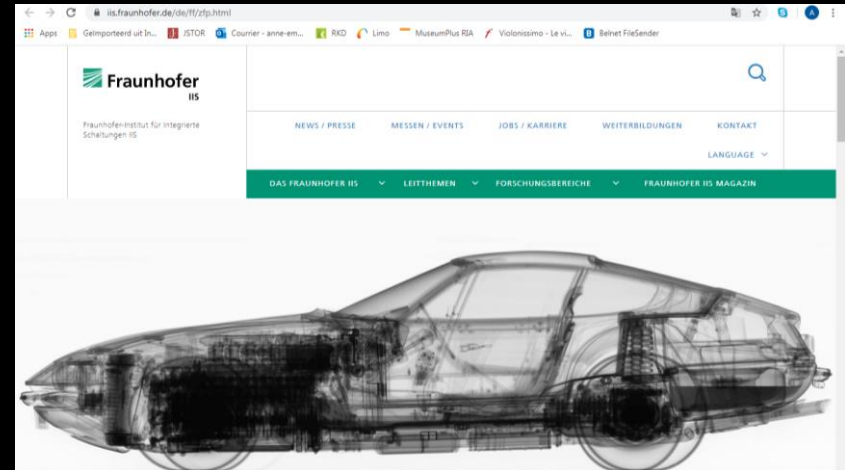

## Scanners médicaux

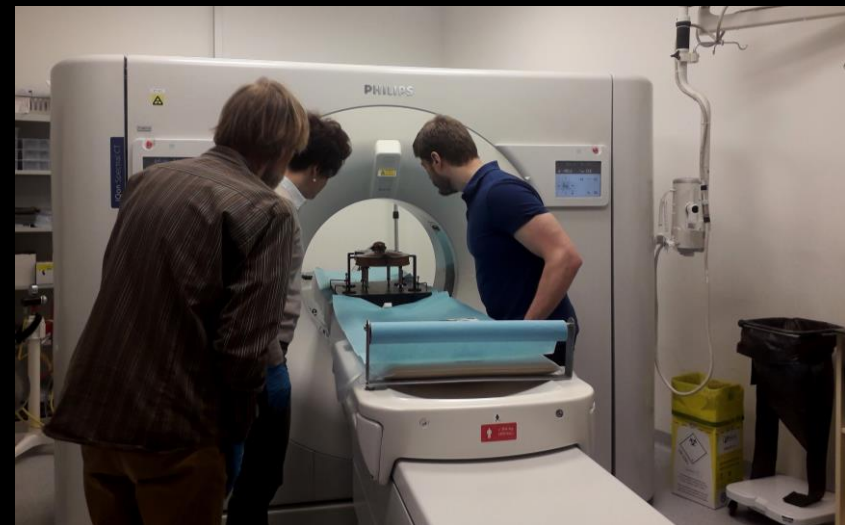

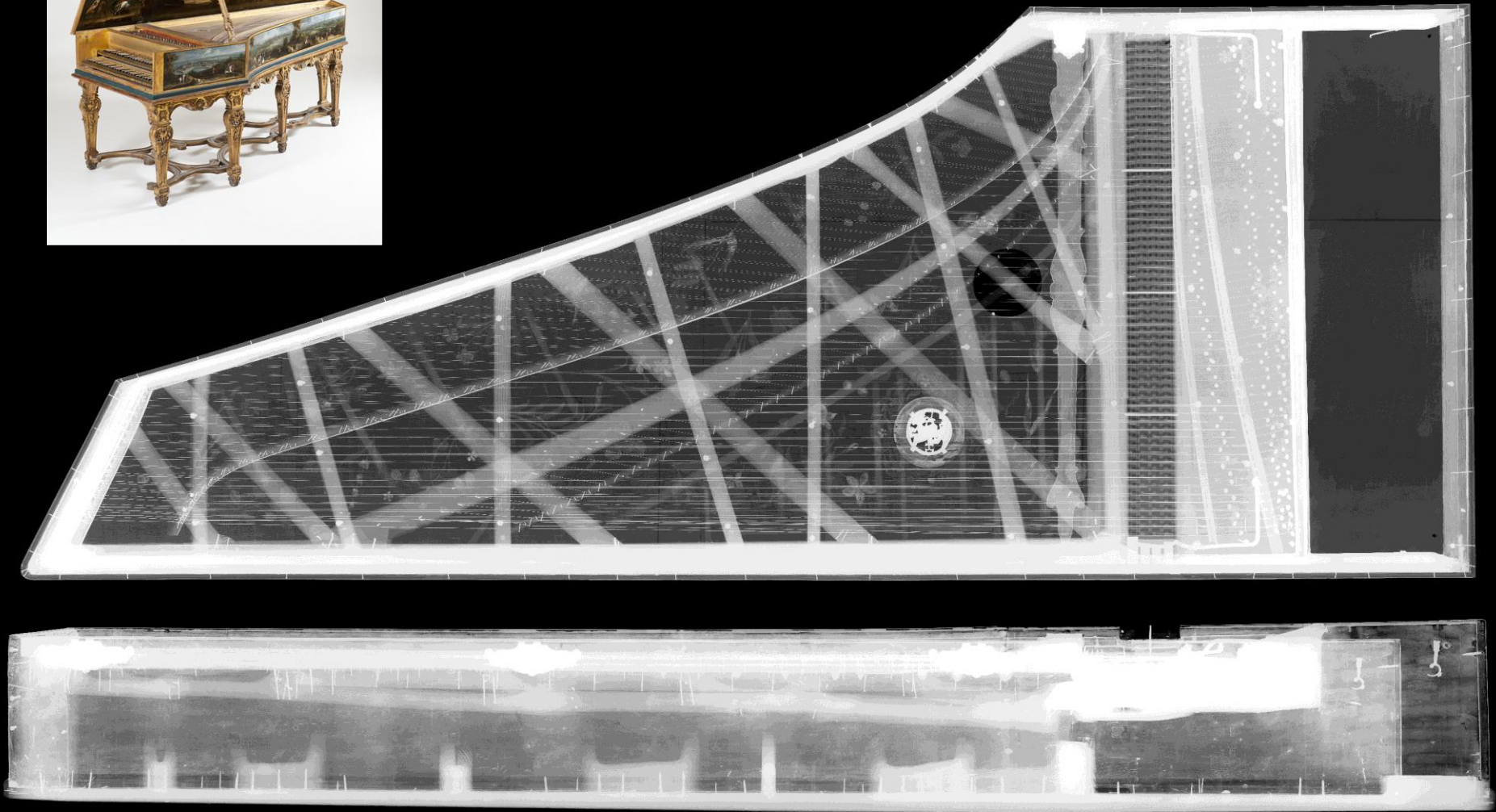

Pascal Taskin (faussetment attribué à Hans Ruckers), Clavecin à double clavier, Paris, c. 1695  
(Bruxelles, Musée des instruments de musique, inv. 3848)

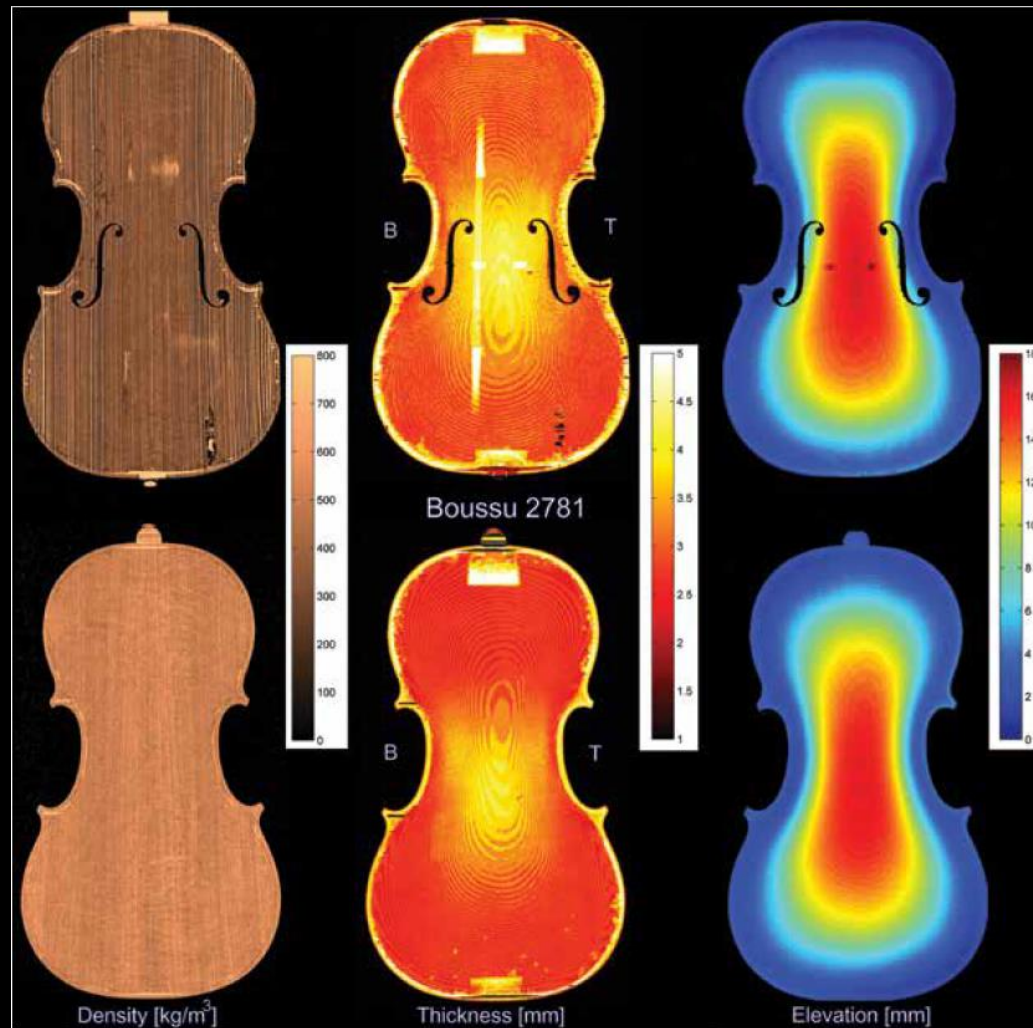

Geerten Verberkmoes, Anne-Emmanuelle Ceulemans, Danielle Balériaux, Berend Stoel, « An Inside Look at Four Historical Violins by Brussels Makers », *The Galpin Society Journal*, LXIX (2016), p. 109-136

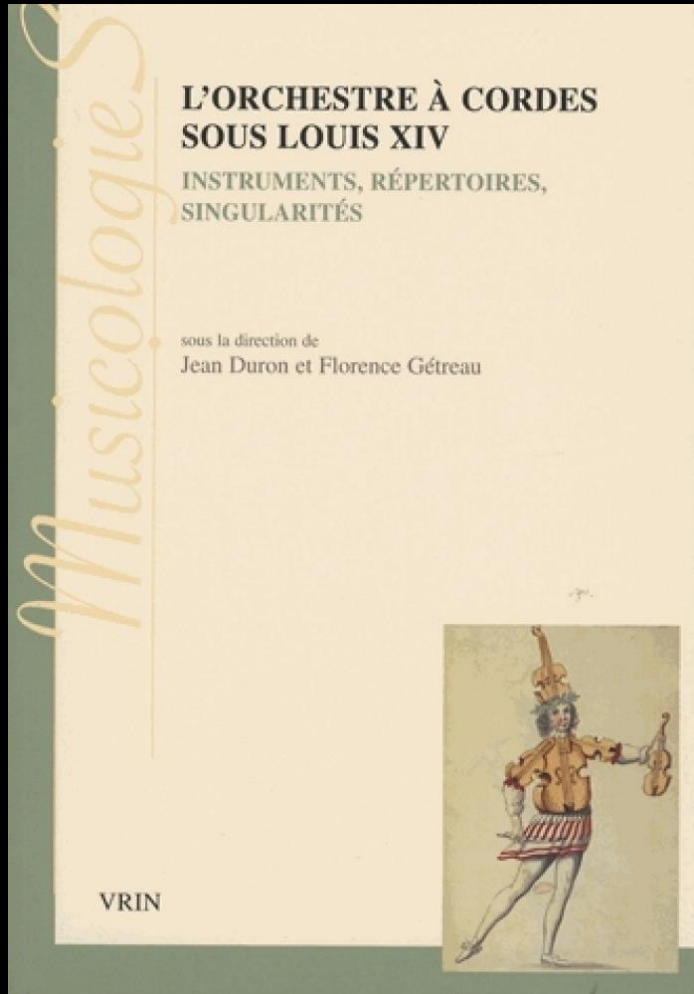

Karel Moens, « Les voix médianes dans l'orchestre français sous le règne de Louis XIV », *L'orchestre à cordes sous Louis XIV. Instruments, répertoires, singularités*, dir. J. Duron – F. Gétreau, Paris, 2015, p. 119-138.



Joseph Darche, Violon, 1857

Hilaire Darche, Alto, Bruxelles, 1912

Hilaire Darche, Violoncelle, Bruxelles, 1912

(MIM, inv. 2015.1273, 3507 et 3514)

# Quatuor à l'italienne

Violon I

Violon II

Alto

Violoncelle

The image displays a musical score for a string quartet, titled "Quatuor à l'italienne". It consists of four staves, each representing a different instrument: Violon I, Violon II, Alto, and Violoncelle. Each staff begins with a double bar line, followed by a half note, a quarter note, another quarter note, and finally a half note. The notes are arranged in a way that suggests a specific harmonic progression, though the exact pitch values are not explicitly labeled with letter names or numbers.



Joseph Haydn, Quatuor op. 72 n° 2 « Les Quintes », Zagreb Quartet



Gaspar Borbon (c. 1635-1710)

- Violon, non daté (manche non original)
  - Grand alto/ténor de violon, 1692
  - Basse de violon, 1702 (manche non original)
- (MIM, inv. 2774, 2836, 2879)

# Quintette à la française

dessus

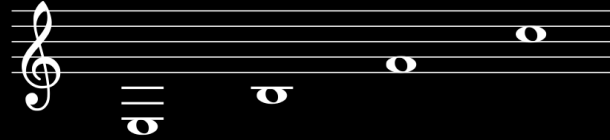

haute-contre

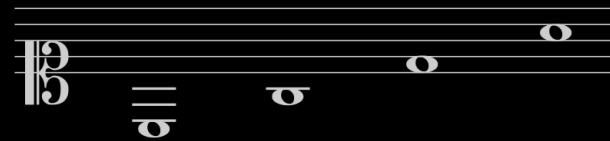

taille

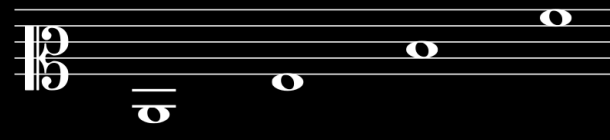

quinte

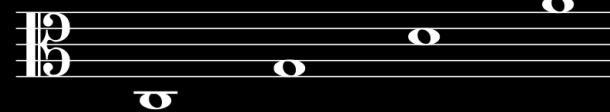

basse

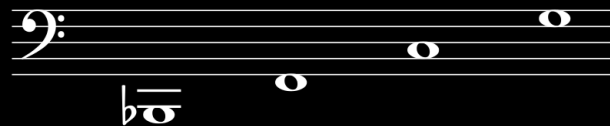

Hauteur de la caisse : actuelle – 35,4 cm < > originale – c. 38 cm



Violon recoupé (= haute-contre ?), France, première moitié du XVIII<sup>e</sup> siècle (Antwerpen, Vleeshuis museum, inv. 1967.001.204), d'après Karel Moens, « Les voix médianes ».

Sonata Violino Primo

Allegro

This image shows the first staff of handwritten musical notation for the Violino Primo part of a Sonata. The notation is written on a five-line staff with a treble clef, a key signature of one sharp (F#), and a common time signature (C). The tempo is marked 'Allegro'. The music consists of a series of eighth and sixteenth notes, with some beamed groups and slurs.

Sonata Violino Secondo

Allegro

This image shows the second staff of handwritten musical notation for the Violino Secondo part of a Sonata. The notation is written on a five-line staff with a treble clef, a key signature of one sharp (F#), and a common time signature (C). The tempo is marked 'Allegro'. The music consists of a series of eighth and sixteenth notes, with some beamed groups and slurs.

Sonata Tenor Viola

Allegro

This image shows the third staff of handwritten musical notation for the Tenor Viola part of a Sonata. The notation is written on a five-line staff with an alto clef (C4), a key signature of one sharp (F#), and a common time signature (C). The tempo is marked 'Allegro'. The music consists of a series of eighth and sixteenth notes, with some beamed groups and slurs.

Sonata Basso Continuo

Allegro

This image shows the fourth staff of handwritten musical notation for the Basso Continuo part of a Sonata. The notation is written on a five-line staff with a bass clef, a key signature of one sharp (F#), and a common time signature (C). The tempo is marked 'Allegro'. The music consists of a series of eighth and sixteenth notes, with some beamed groups and slurs. There are also some numerical figures (6, 7, 6, 6) written above the notes, likely indicating figured bass.

Pietro Antonio Fiocco, *Sonata a 4* (1692-1714)  
(Bruxelles, Bibliothèque du Conservatoire, ms. 33.822)

En 1783, Henri De Croes, maître de la chapelle de la cour à Bruxelles, est amené à rédiger un rapport détaillé sur le fonctionnement de sa chapelle. On y découvre que la chapelle fait appel aux instrumentistes à archet suivants :

premier violon, second violon,  
alto viola, tenore viola, violoncelle,  
grosse basse.



gorge ou ragreyure

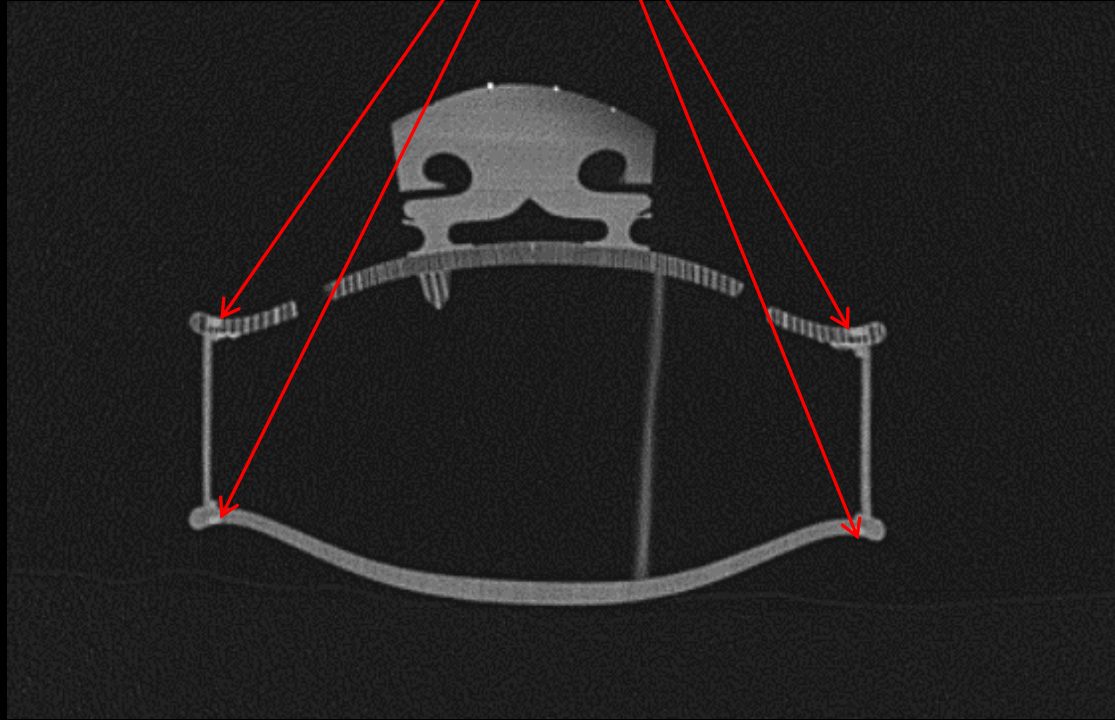

Benoît Joseph Boussu, Violon, Bruxelles, 1750  
(MIM, inv. 2781)



Johannes Theodorus Cuypers, Alto, La Haye, 1761 (MIM inv. 2833)  
Coupe transversale et sagittale

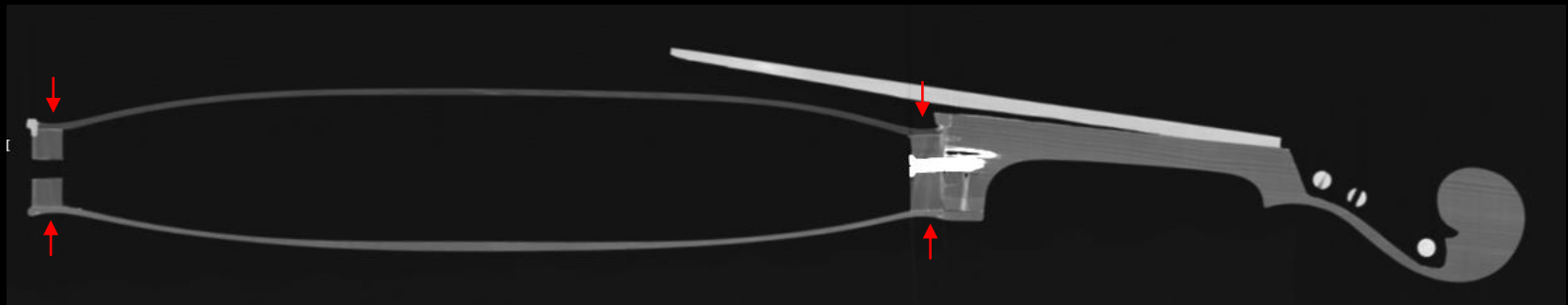
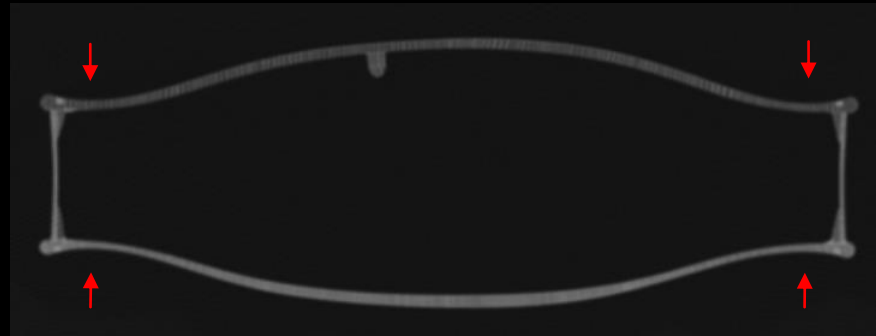

Matthys Hofmans IV (?), "Alto", avant 1679 (MIM inv. 2846)  
Coupe transversale et sagittale

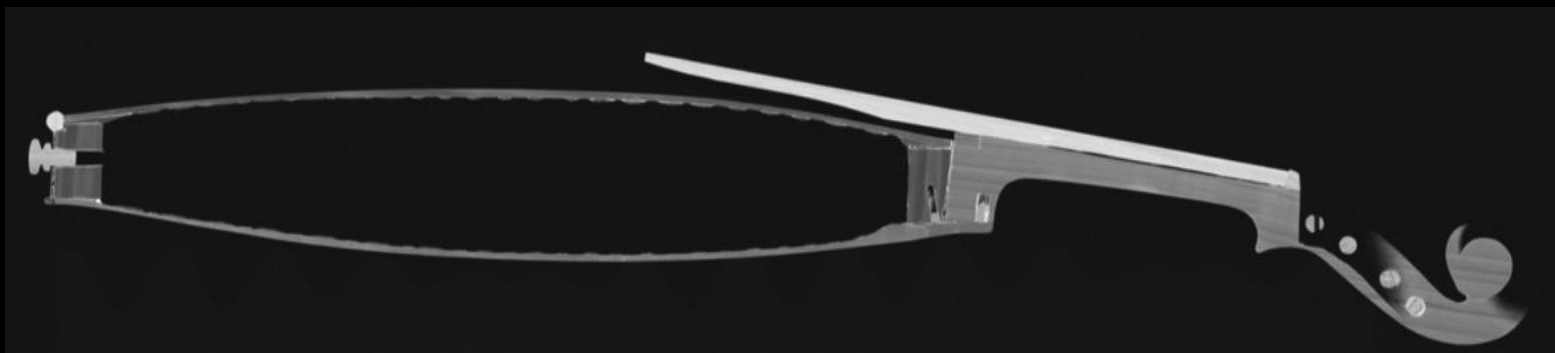
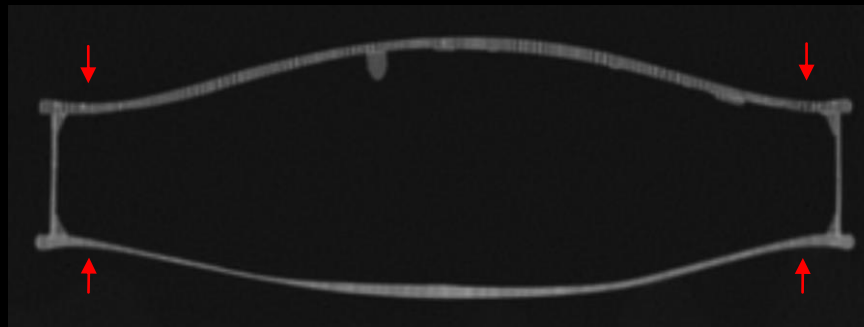

Renaud Lothaire, *Characterization of violins: a digital tool at the service of organology*, UCLouvain, 2019

MIM, inv. no. 2833 (Cuypers)

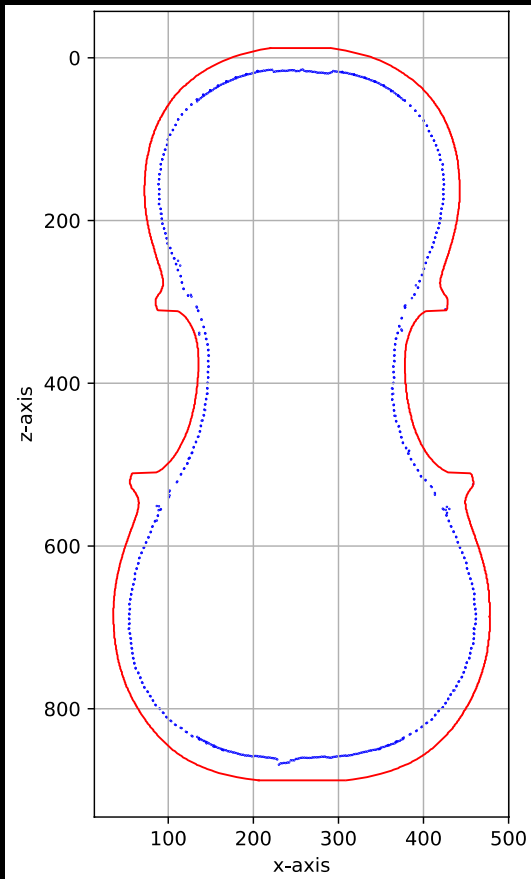

MIM, inv. no. 2846 (Hofmans)

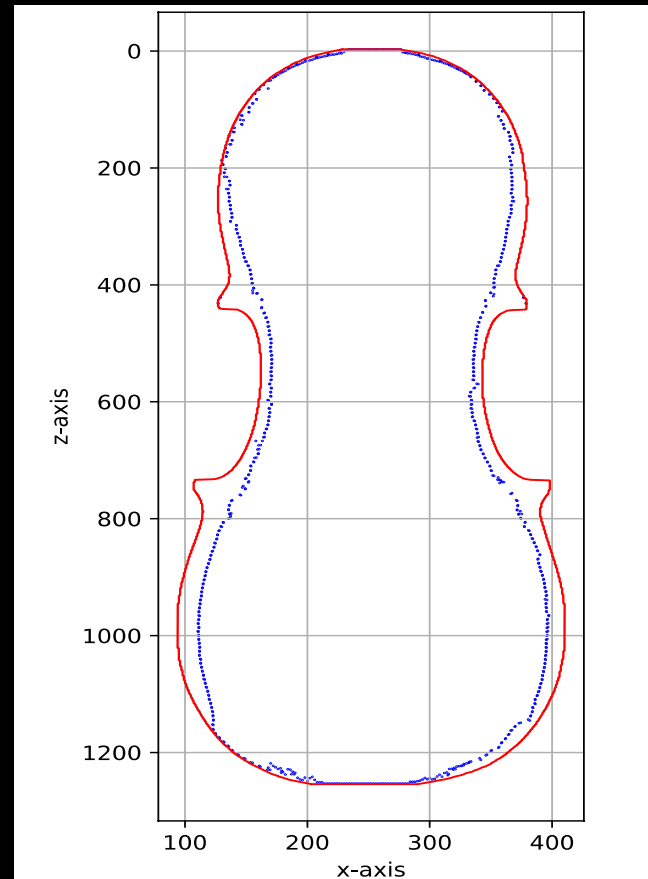



# BORBON

- ◇ Famille de luthiers à la cour de Bruxelles aux XVIIe et XVIIIe siècles
- ◇ Peter I, II (?) et Gaspar
- ◇ Gaspar: né vers 1635 (Bruxelles), mort 25/11/1710 (Bruxelles)
- ◇ 1664 et 1673: « réparateur des instruments » de la chapelle de la cour





VIOLON MIM 01 - 4/05/2019 10:08:57 - ABDOMEN, iDose (4)

4/05/2019  
4/05/2019 10:01:16  
Violon  
CT: 1 series  
ABDOMEN, iDose (4)  
1634

Im: 691/1634  
Se: 202

VIOLON MIM 01  
2836  
4/05/2019 O  
UCL St LUC  
8824  
Violon  
ABDOMEN, iDose (4)  
ABDOMEN

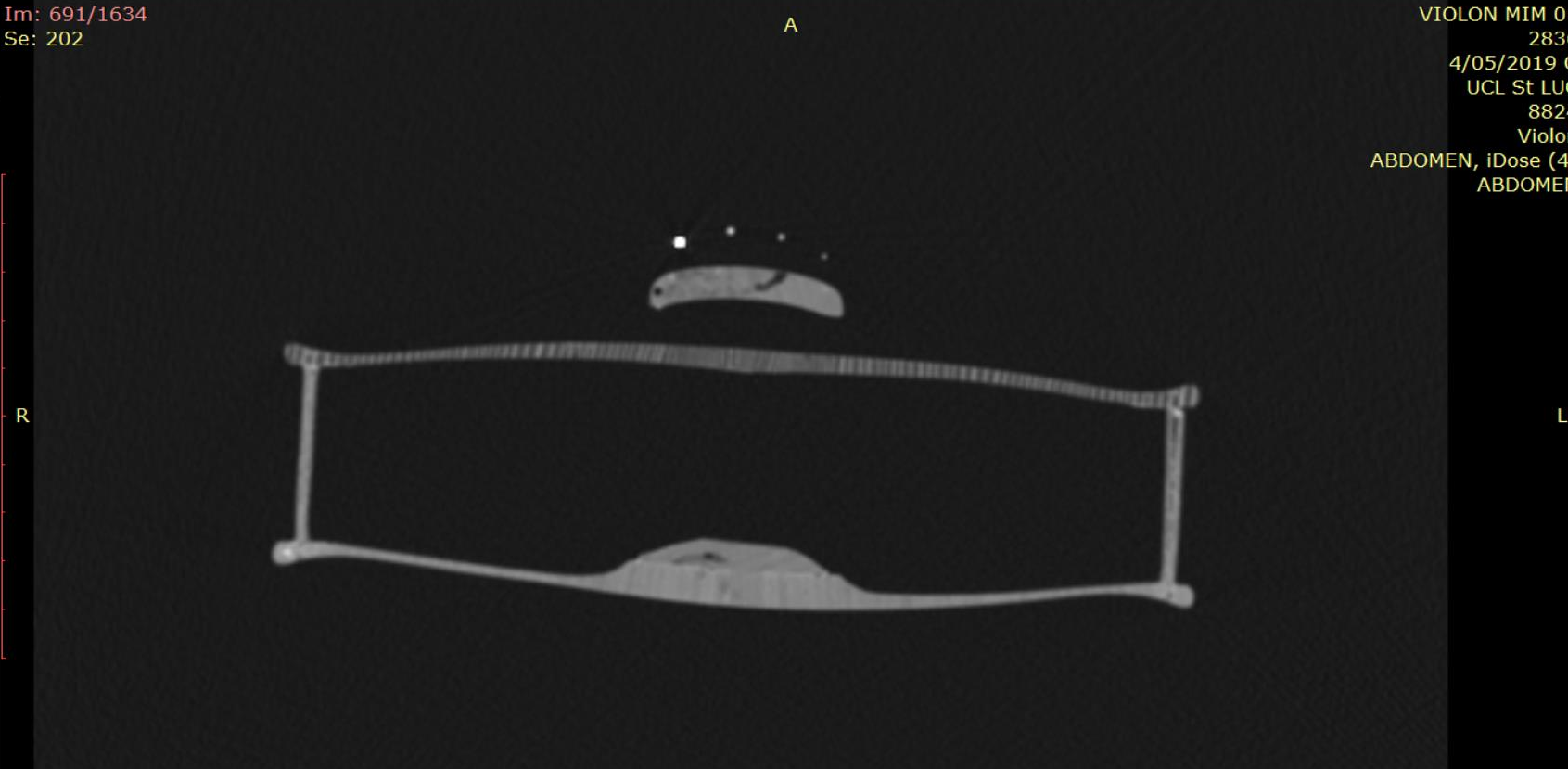

WL: -400 WW: 1500 [CT Lungs]  
T: 0.9mm L: 420.9mm

39mA 140kV  
4/05/2019 10:08:57

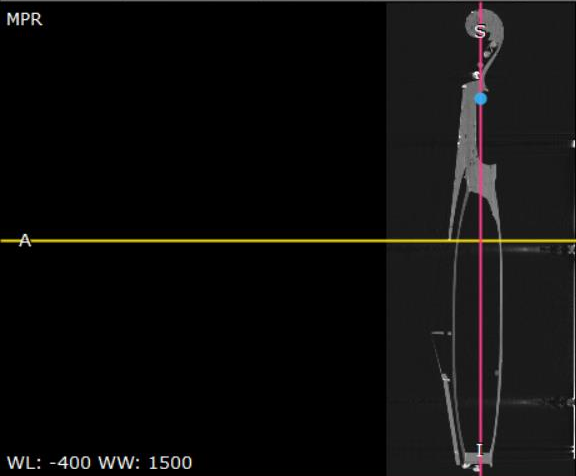

WL: -400 WW: 1500

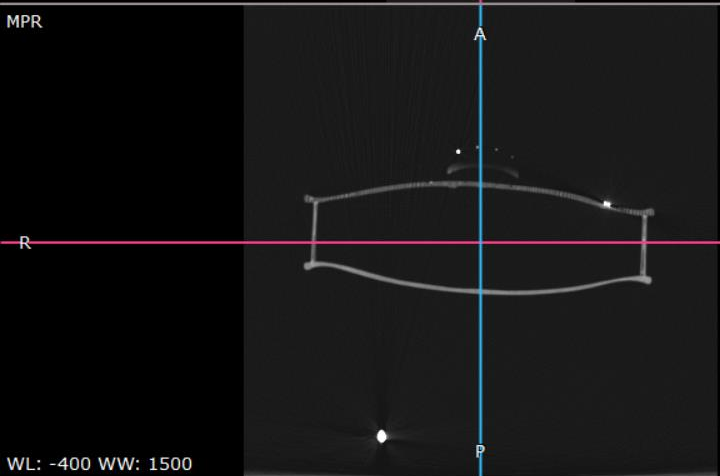

WL: -400 WW: 1500

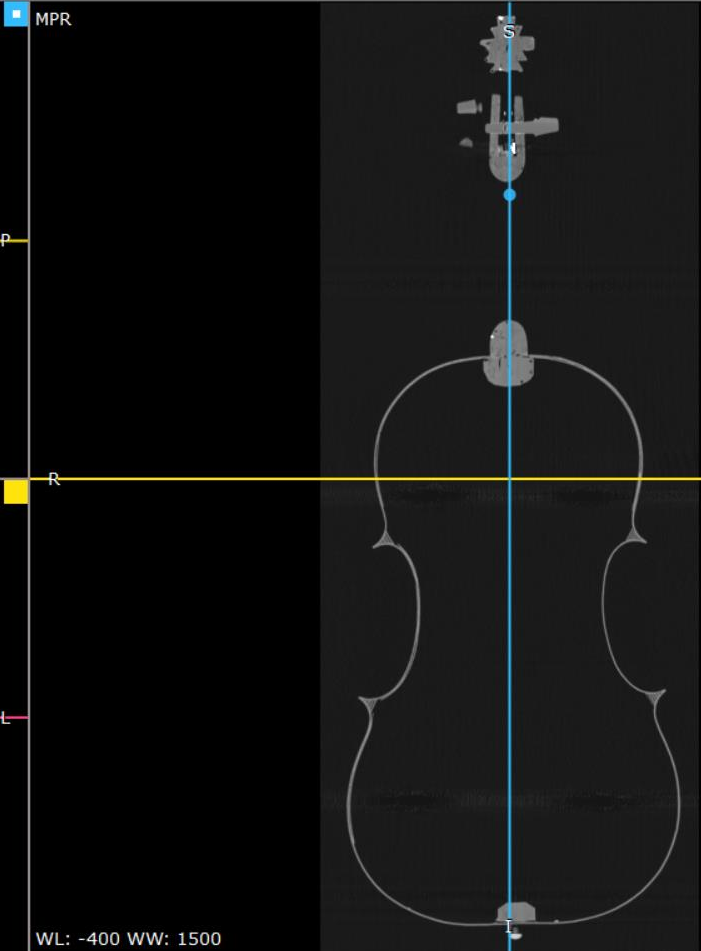

WL: -400 WW: 1500



VR

ASL

S

I

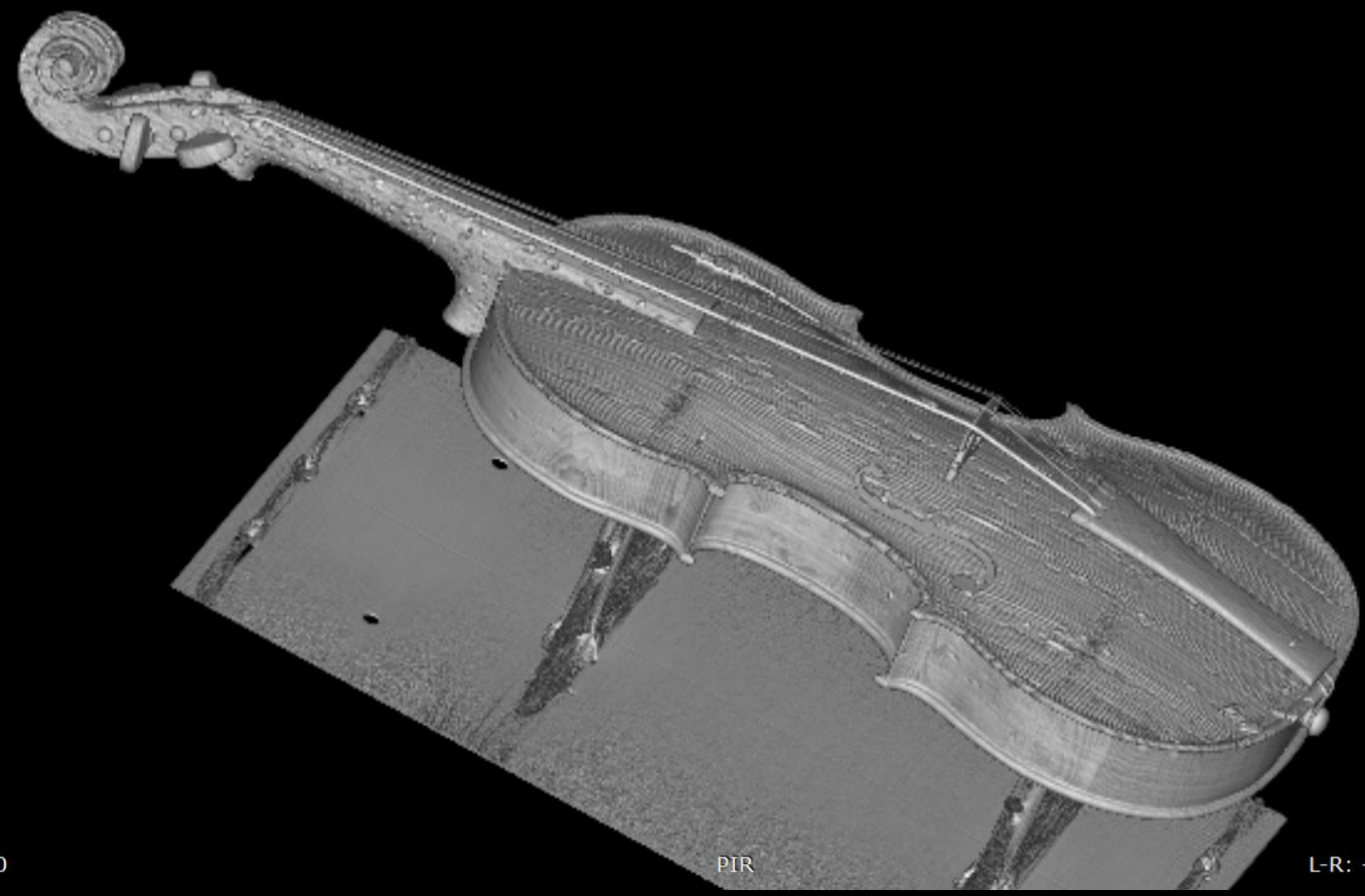

WL: -50 WW: 1500

PIR

L-R: -57.1° S-I: -6.9° Roll: 61.4°

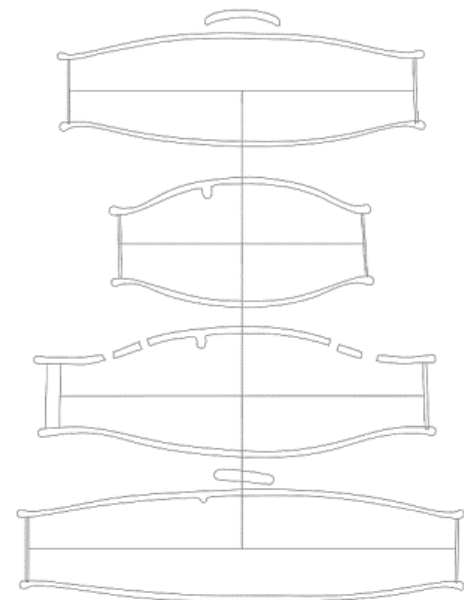
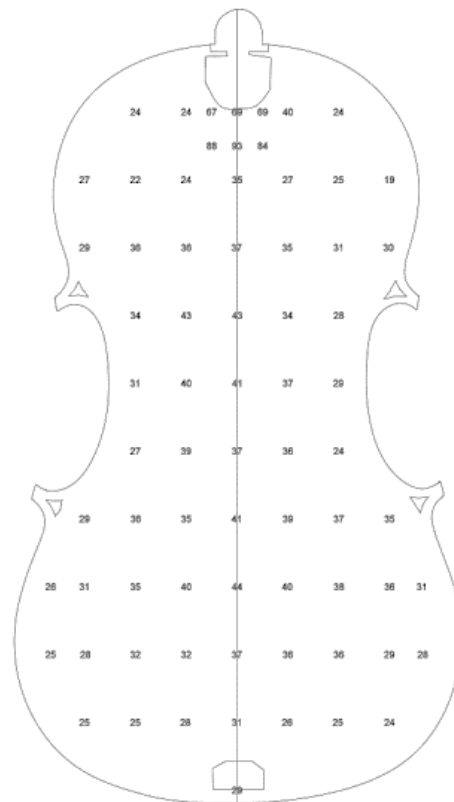
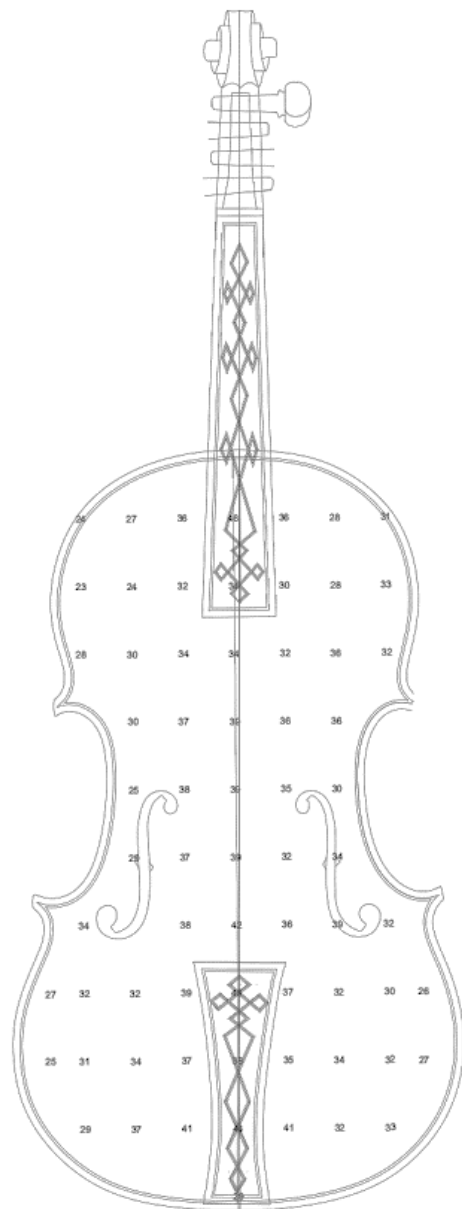

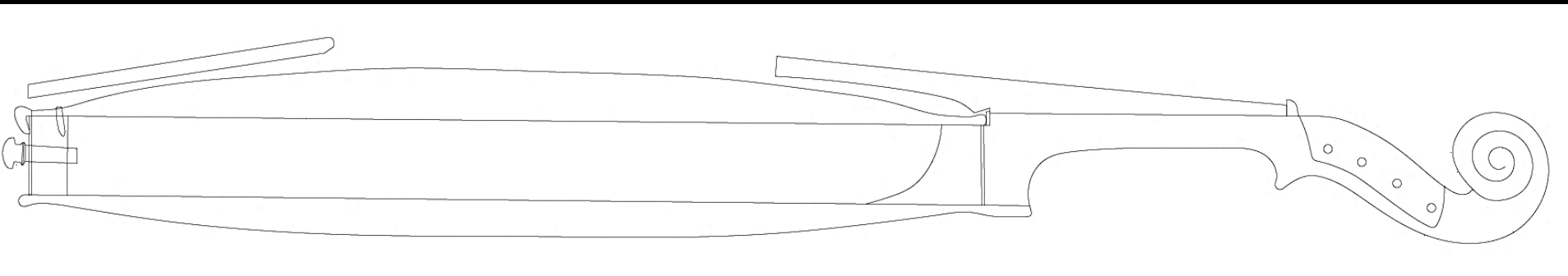
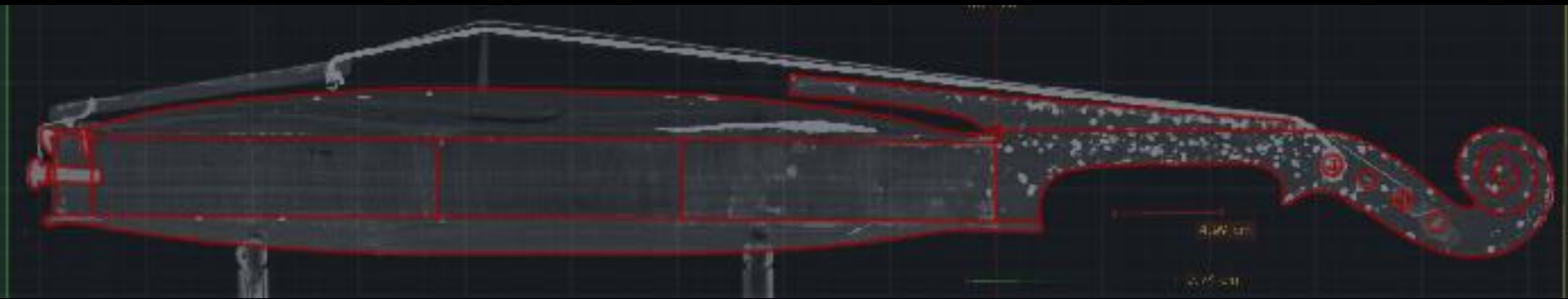
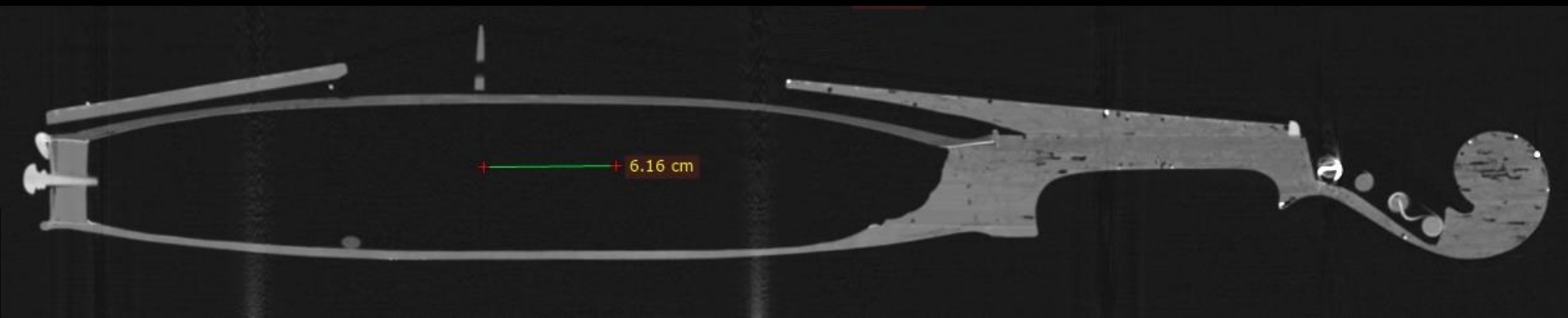

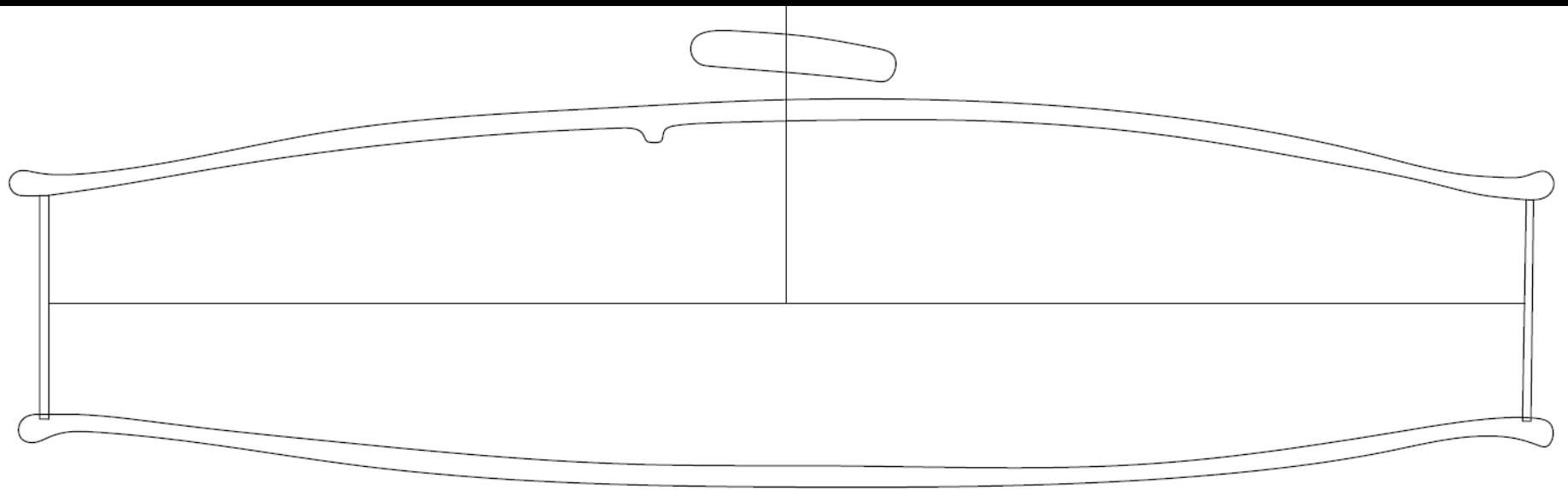
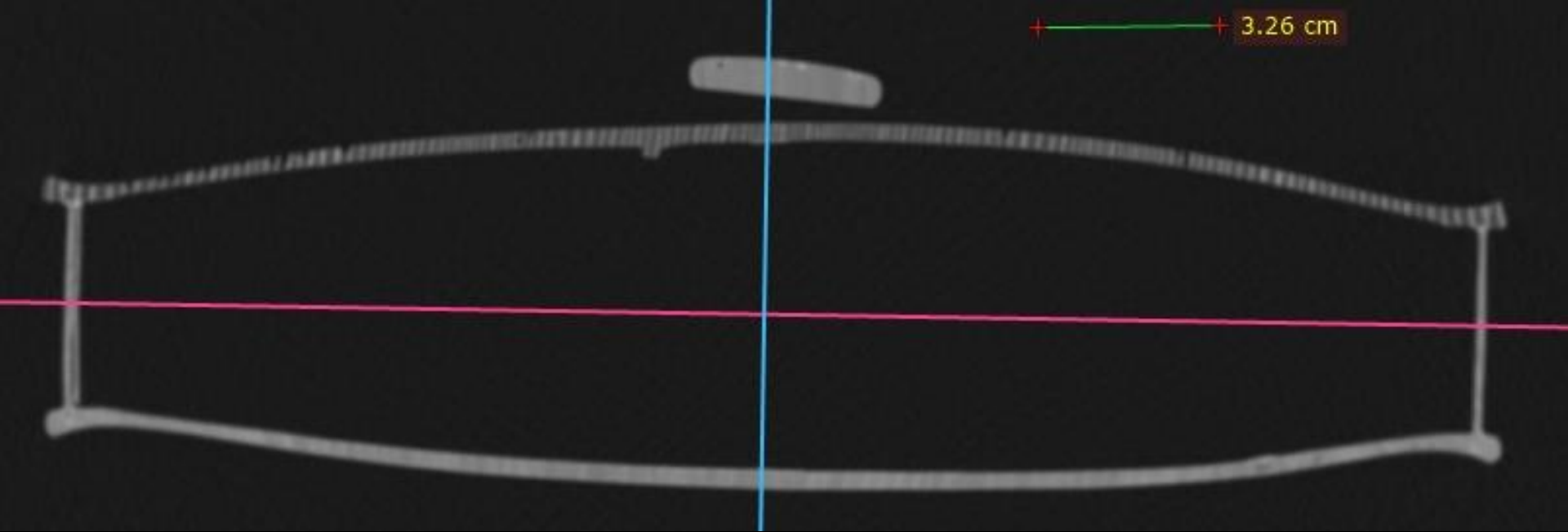

Autodesk AutoCAD 2019 - STUDENT VERSION planAlt.dwg

Home Insert Annotate Parametric View Manage Output Add-ins Collaborate Express Tools Featured Apps

Line Polyline Circle Arc Move Rotate Trim Copy Mirror Fillet Stretch Scale Array Text Dimension Table Layer Properties Match Layer

Draw Modify Annotation Layers Block

Start snoeck plan 1373\* x planAlt\* x

DRAWING RECOVERY MANAGER

Backup Files  
oultinek

Details

Preview

External References

PROPERTIES

No selection

General

- Color: ByLayer
- Layer: rib
- Linetype: ByLayer
- Linetype scale: 1
- Lineweight: ByLayer
- Transparency: ByLayer
- Thickness: 0

3D Visualization

- Material: ByLayer

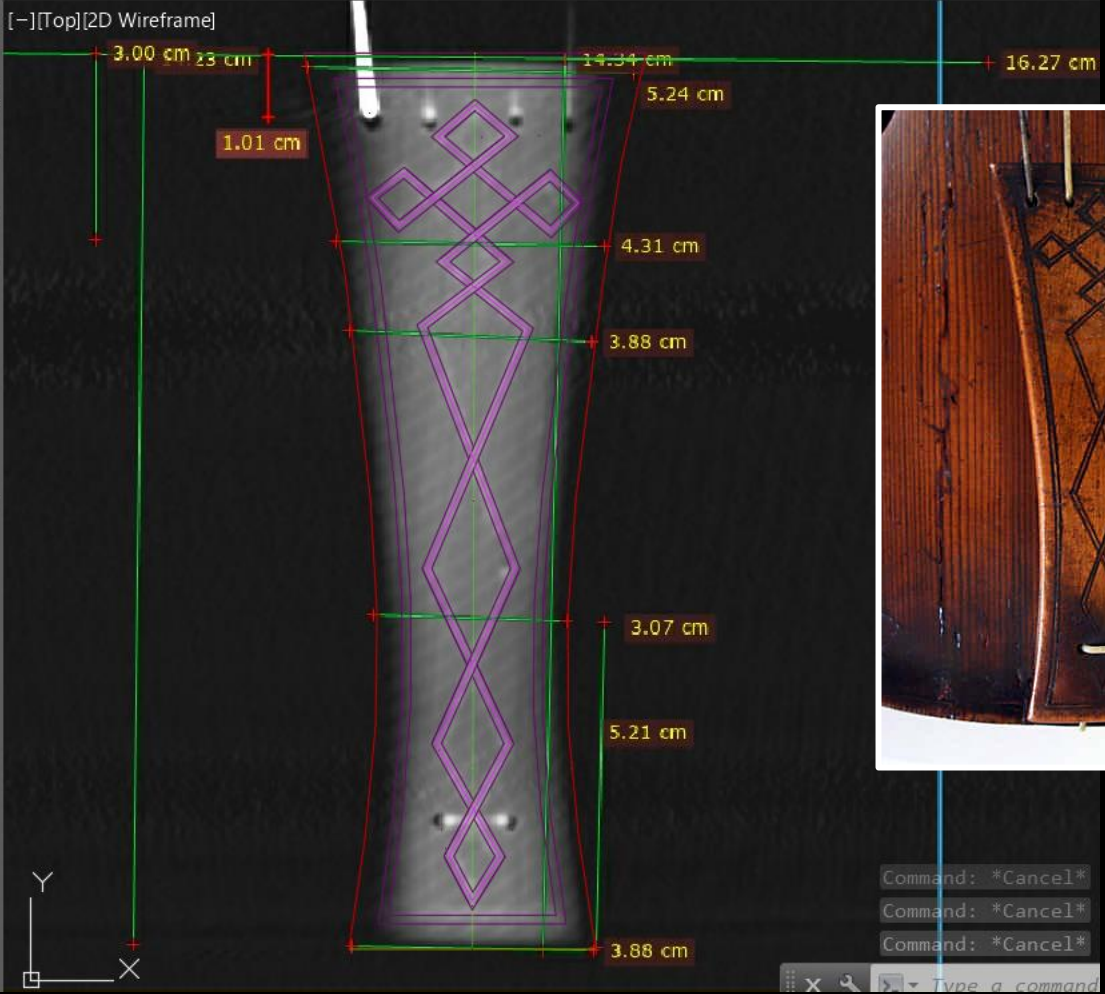



VR



R

L

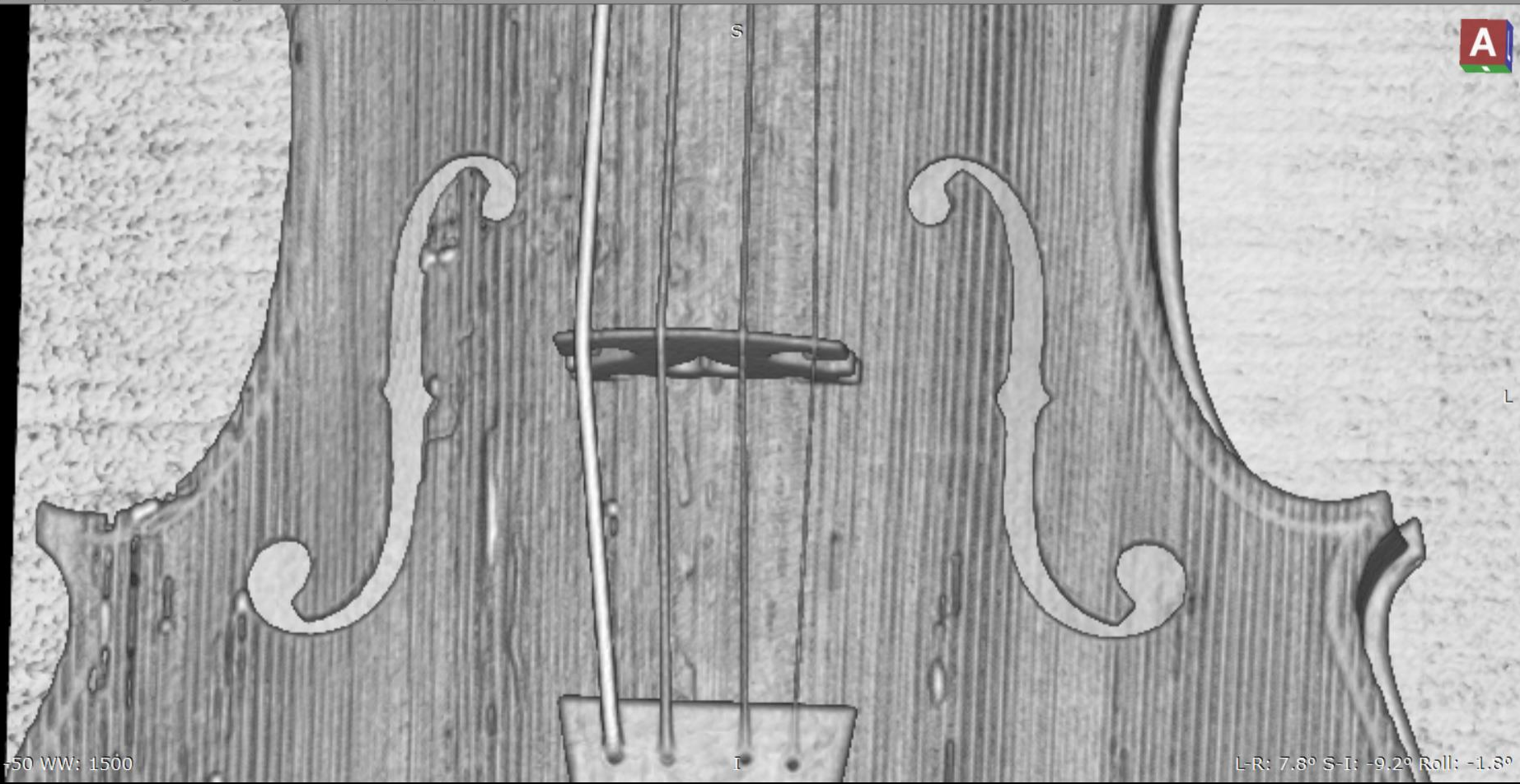

WL: 750 WW: 1500

L-R: 7.8° S-I: -9.2° Roll: -1.3°

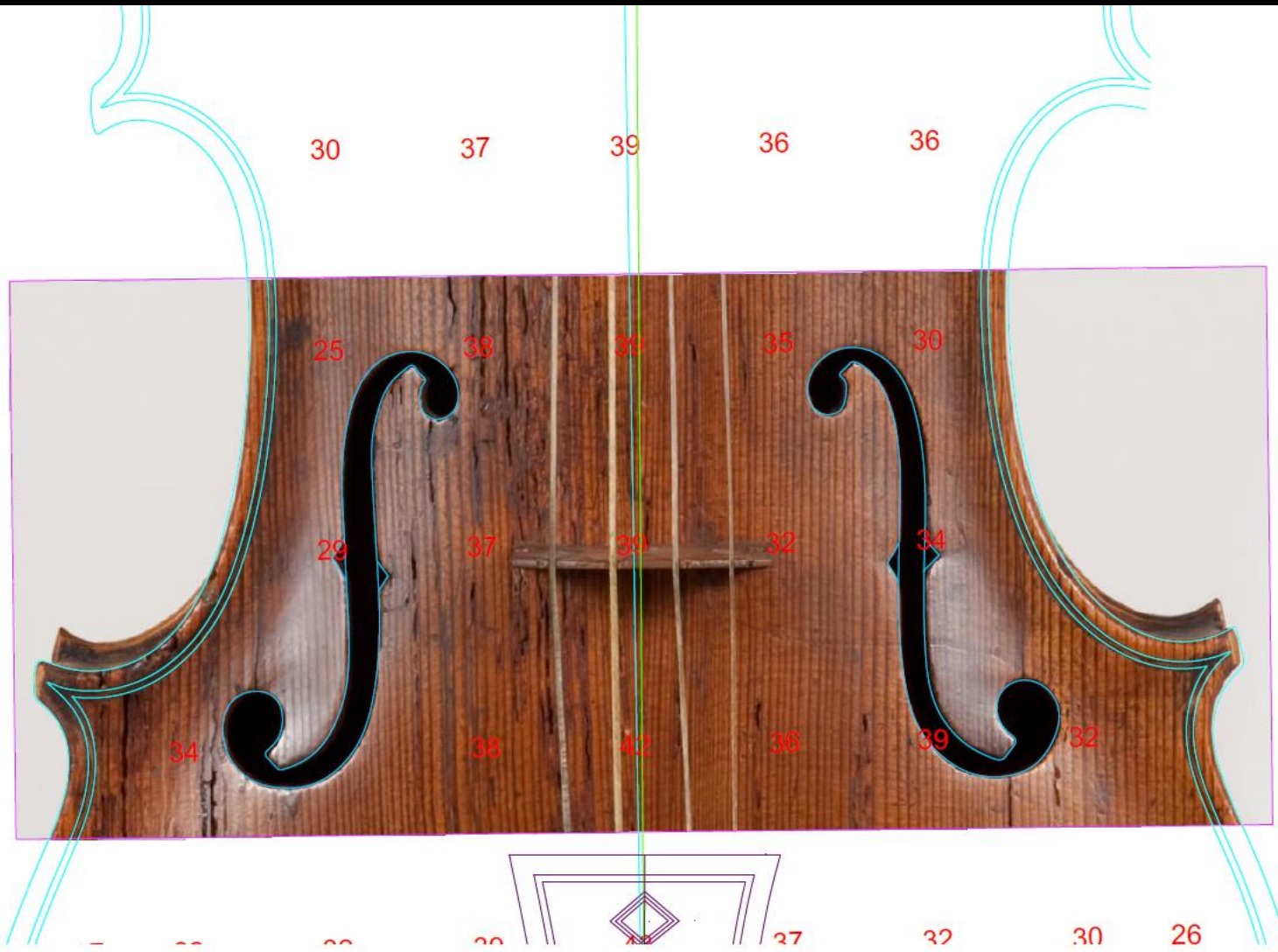

S

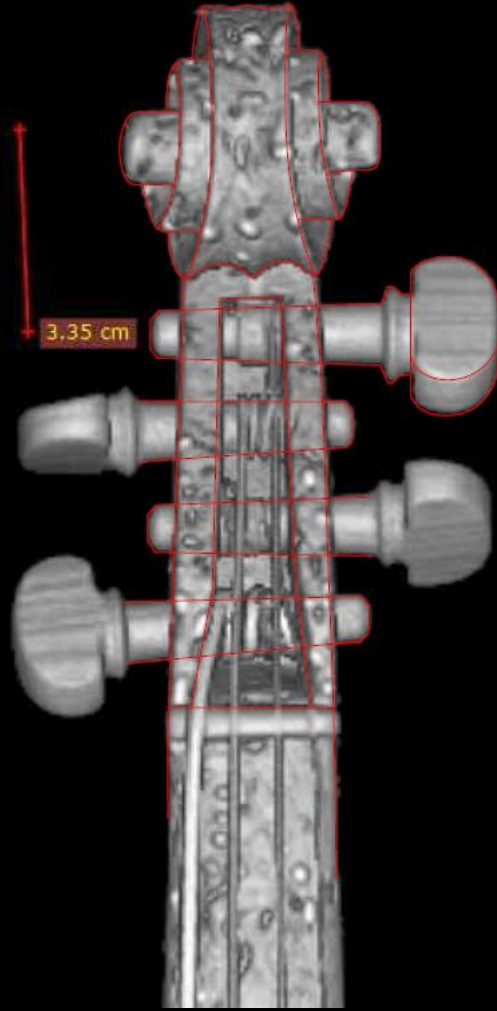

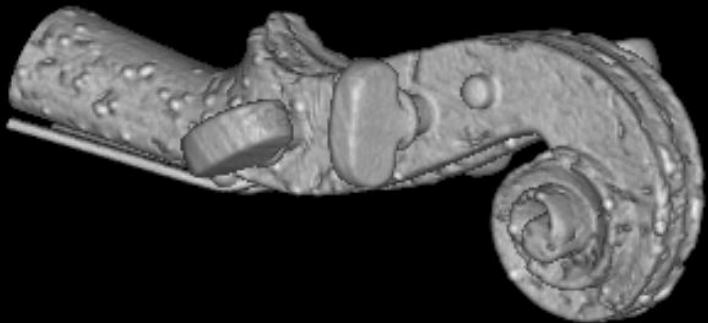

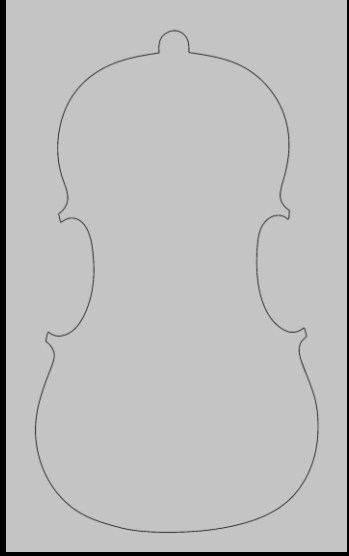
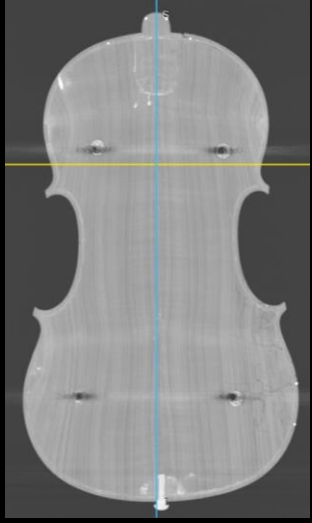

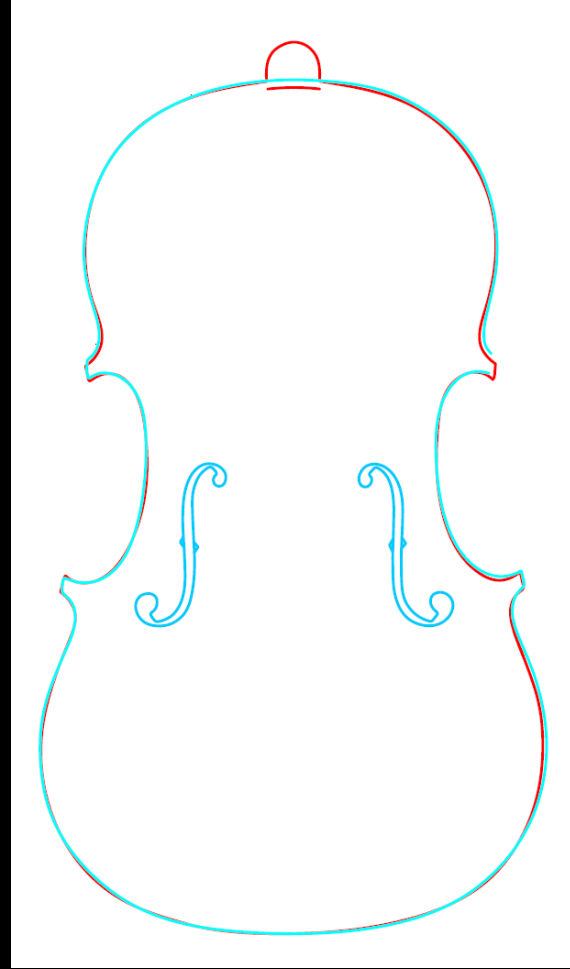
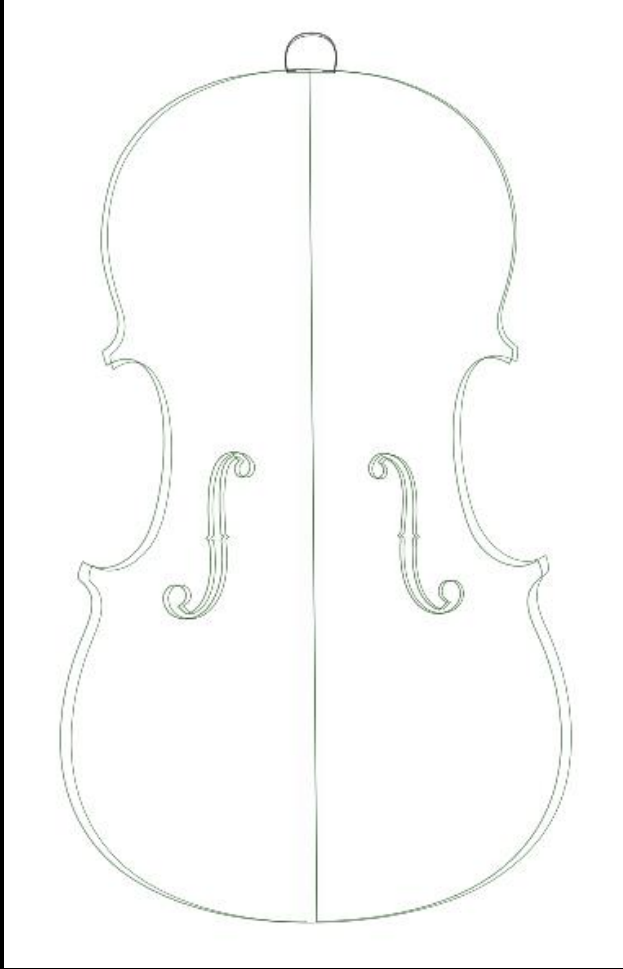

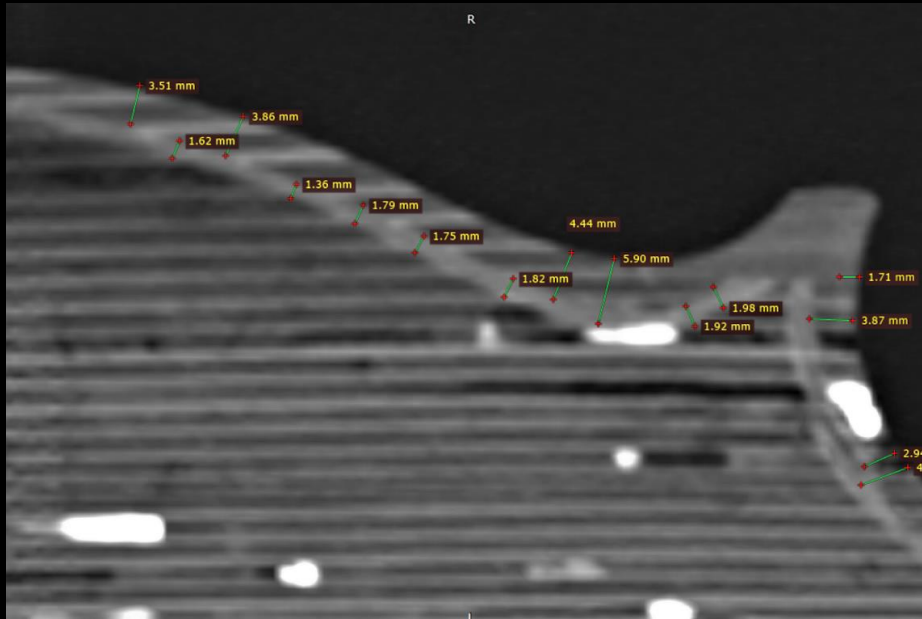

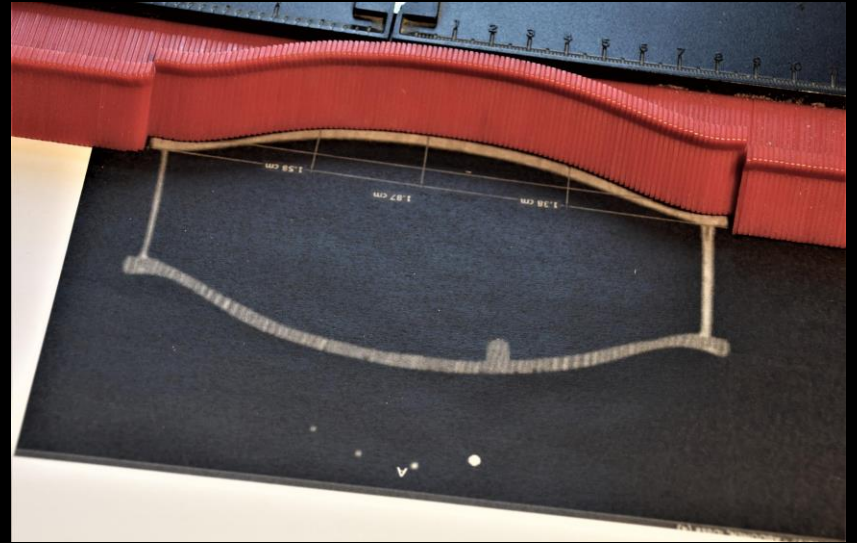

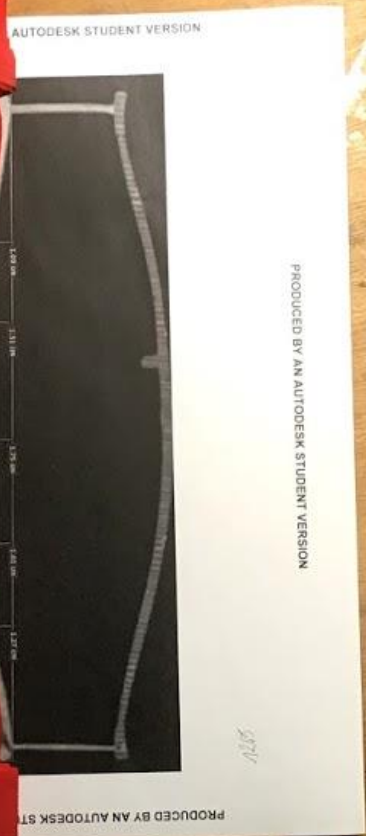



Im: 1003/1634  
Se: 202

VIOLON MIM 01  
2836  
4/05/2019 O  
UCL St LUC  
8824  
Violon  
ABDOMEN, iDose (4)  
ABDOMEN

A

R

L

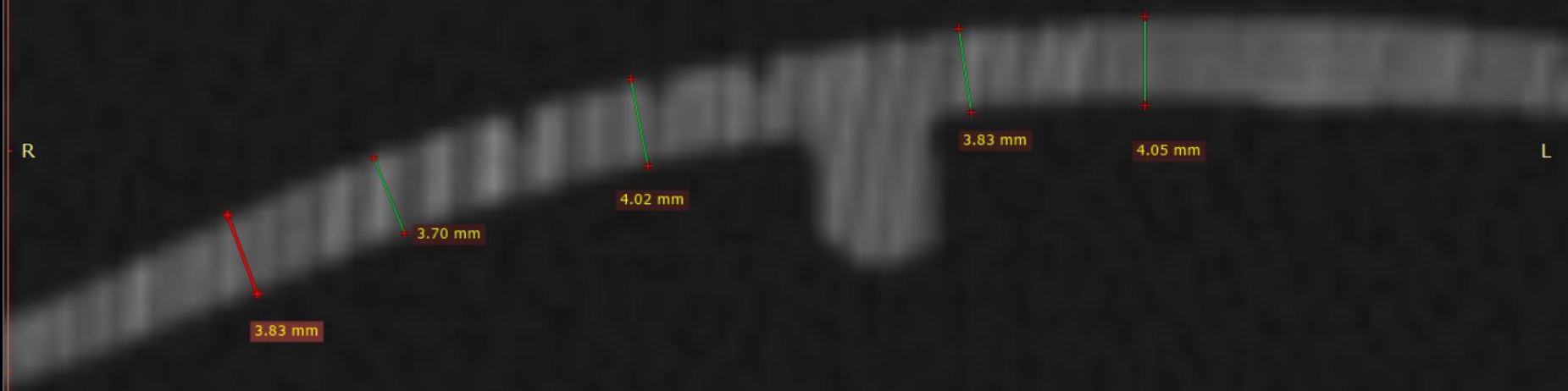

WL: -400 WW: 1500 [CT Lungs]  
T: 0.9mm L: 280.5mm

P

17mA 140kV  
4/05/2019 10:08:57

Slide NO. Hand w/6

ACHTERBLAD alles in mm

Slide NO.	1	2	3	4	5	6	7	8	9	10	11	12	13	14	15	16	17	18	19	20	21	22	23	24	25	26	27	
597	1	2	3																									
619																												
641																												
663																												
685																												
707																												
730																												
752																												
774																												
796																												
819																												
841																												
863																												
885																												
907																												
930																												
952																												
974																												
996																												
1018																												
1041																												
1063																												
1085																												
1107																												
1130																												
1153																												
1175																												
1197																												
1219																												
1241																												
1264																												
1286																												
1308																												
1330																												
1352																												
1375																												
1397																												
1419																												
1441																												
1463																												

HOEK HOEK HOEK HOEK

INTERFERENTIE VAN METALLEN DOUCHEN

DISKANT

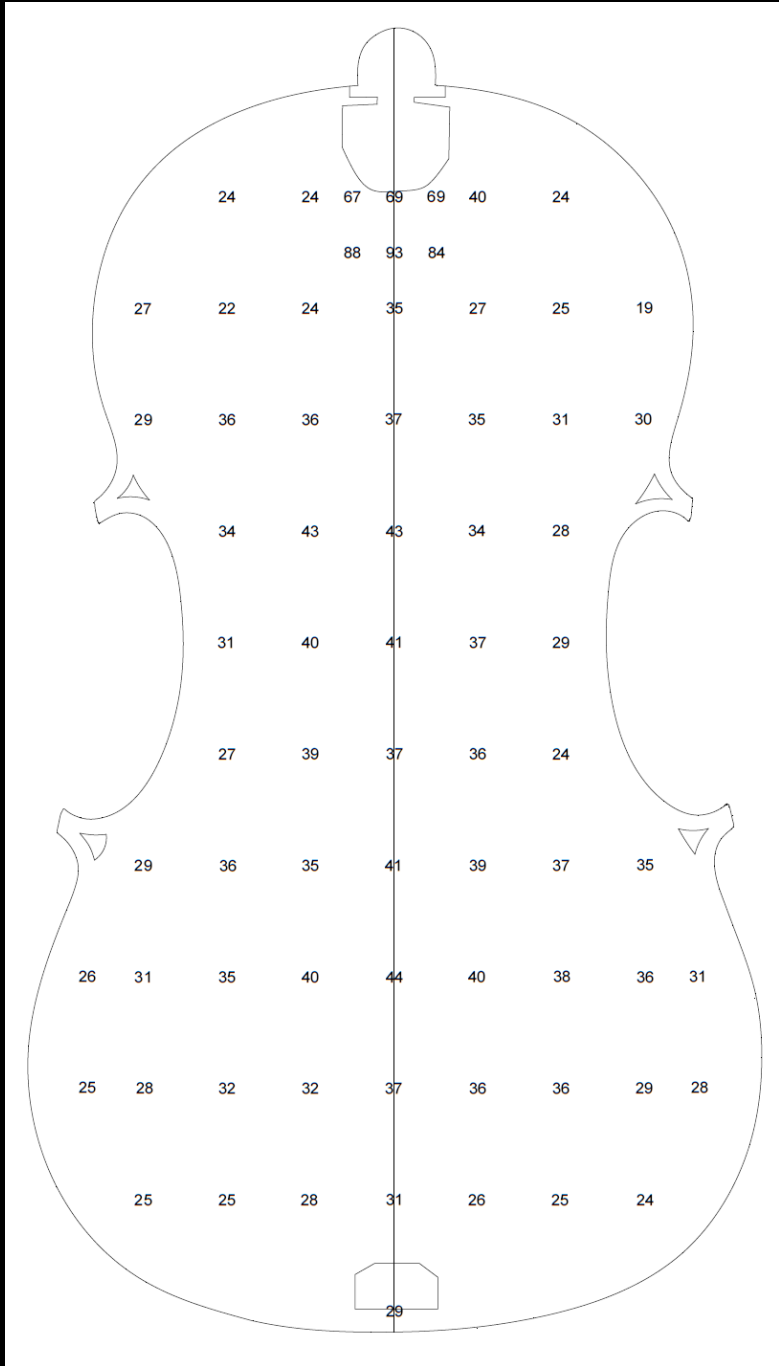

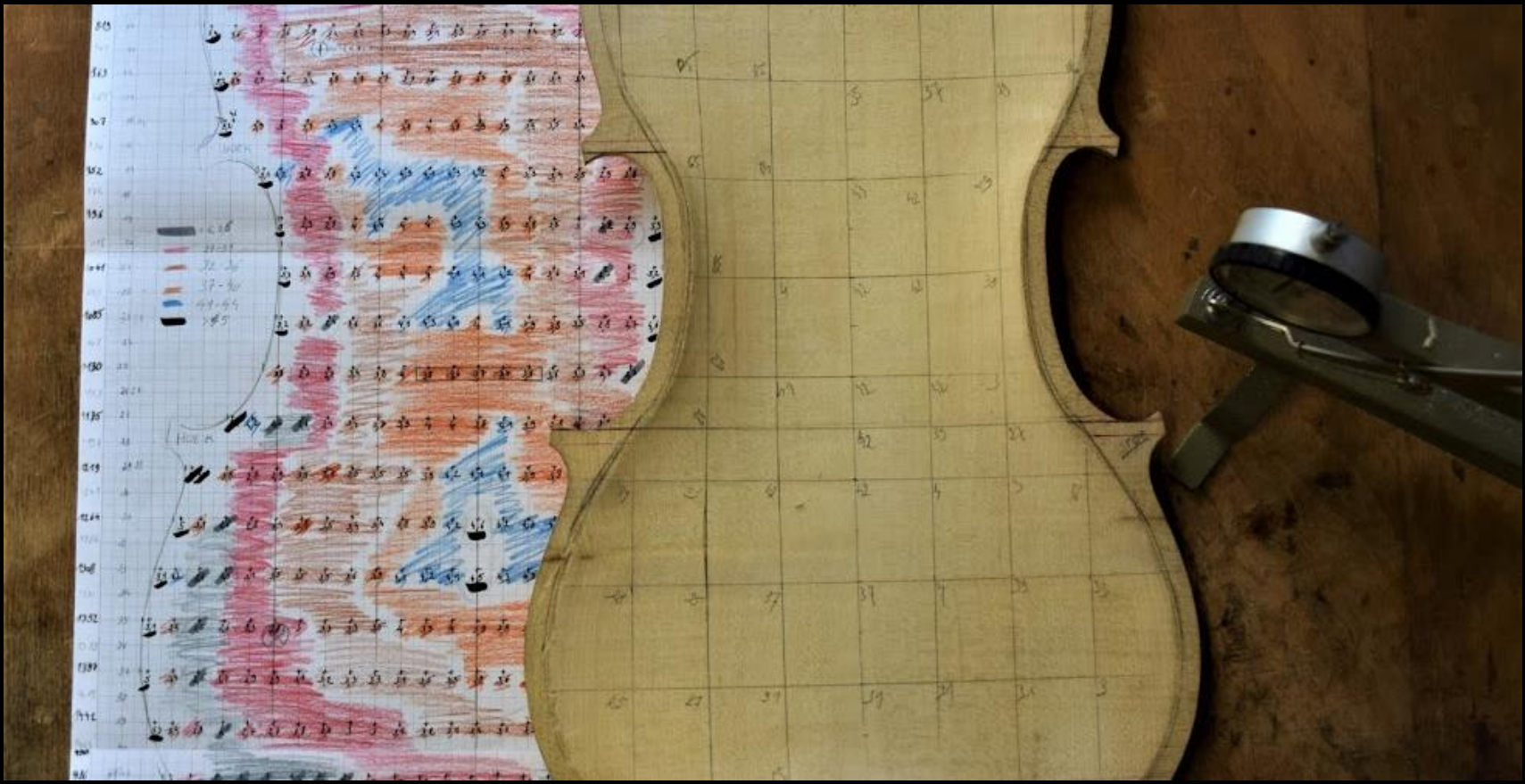



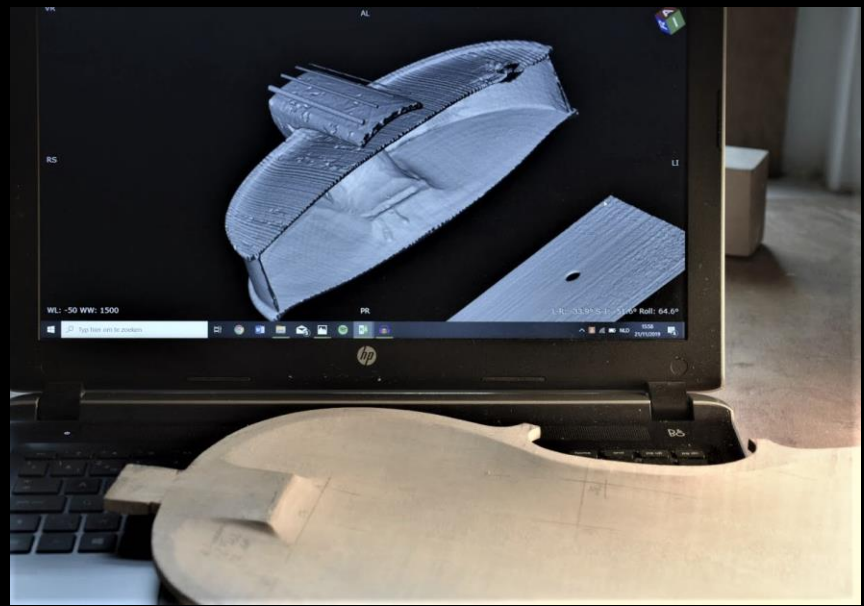
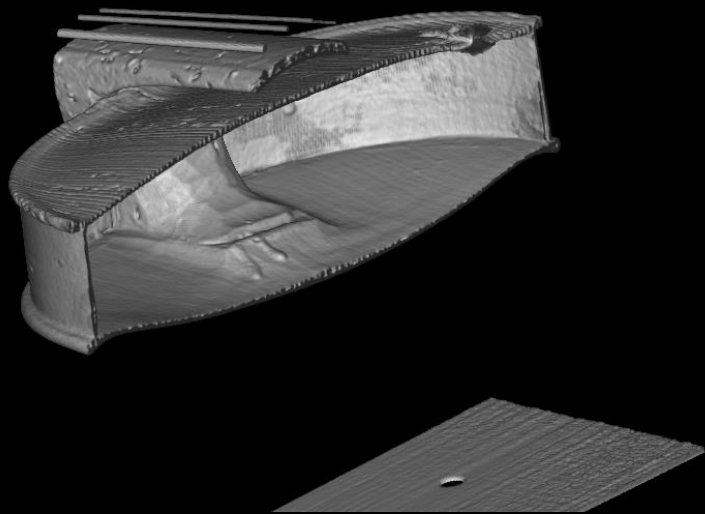

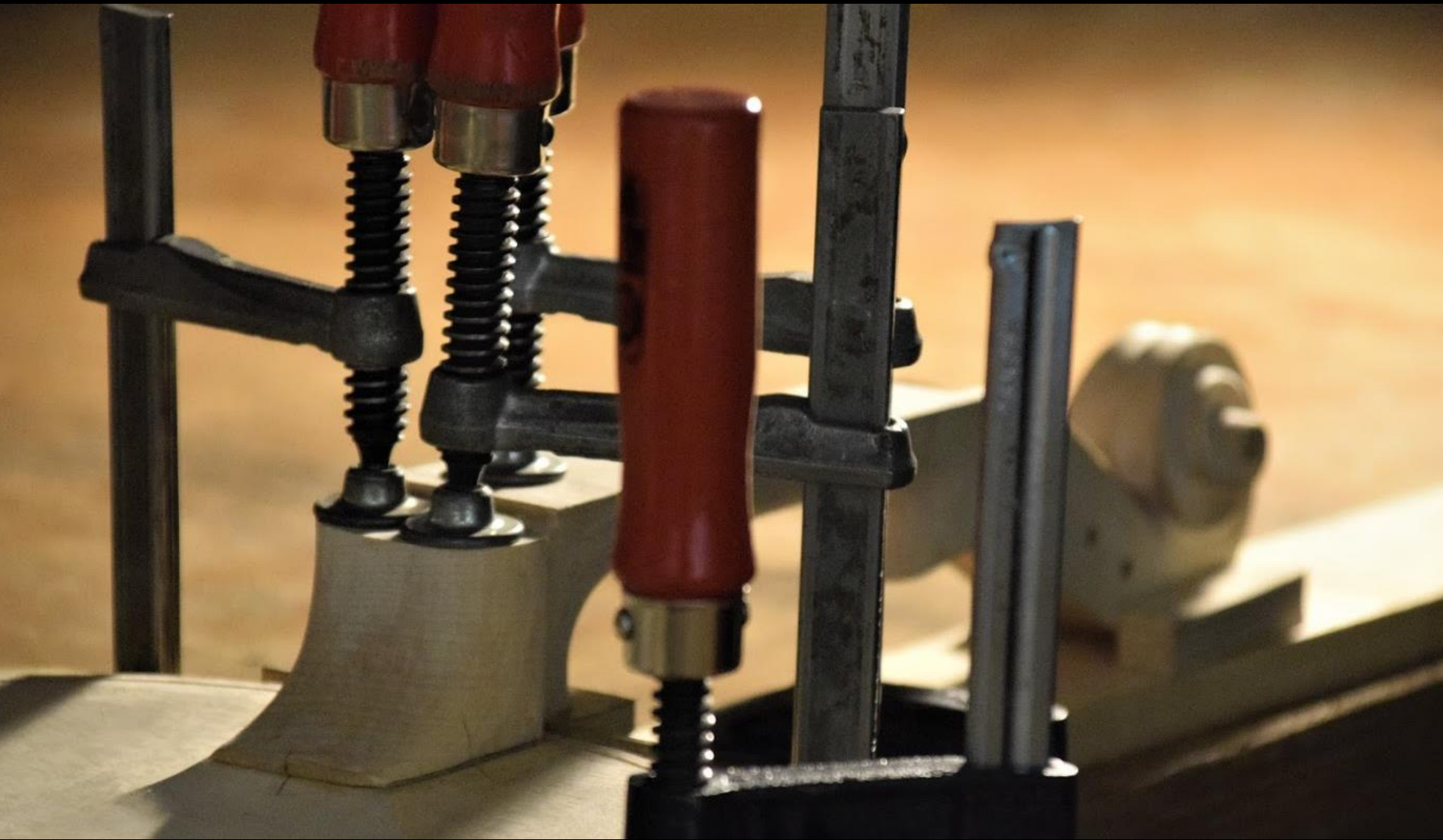

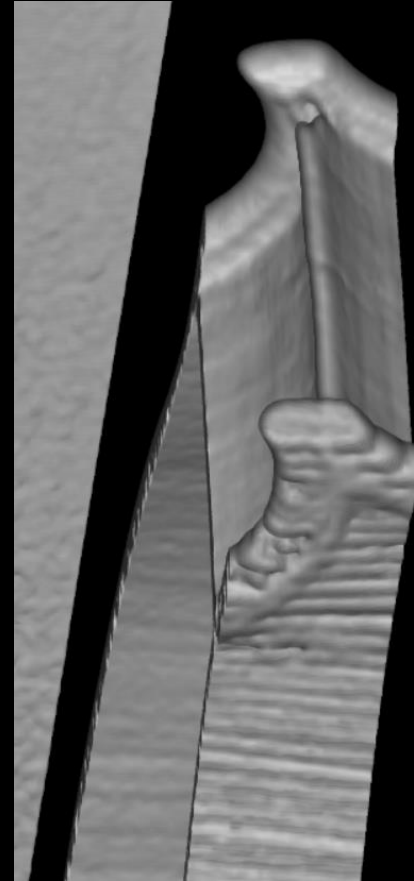





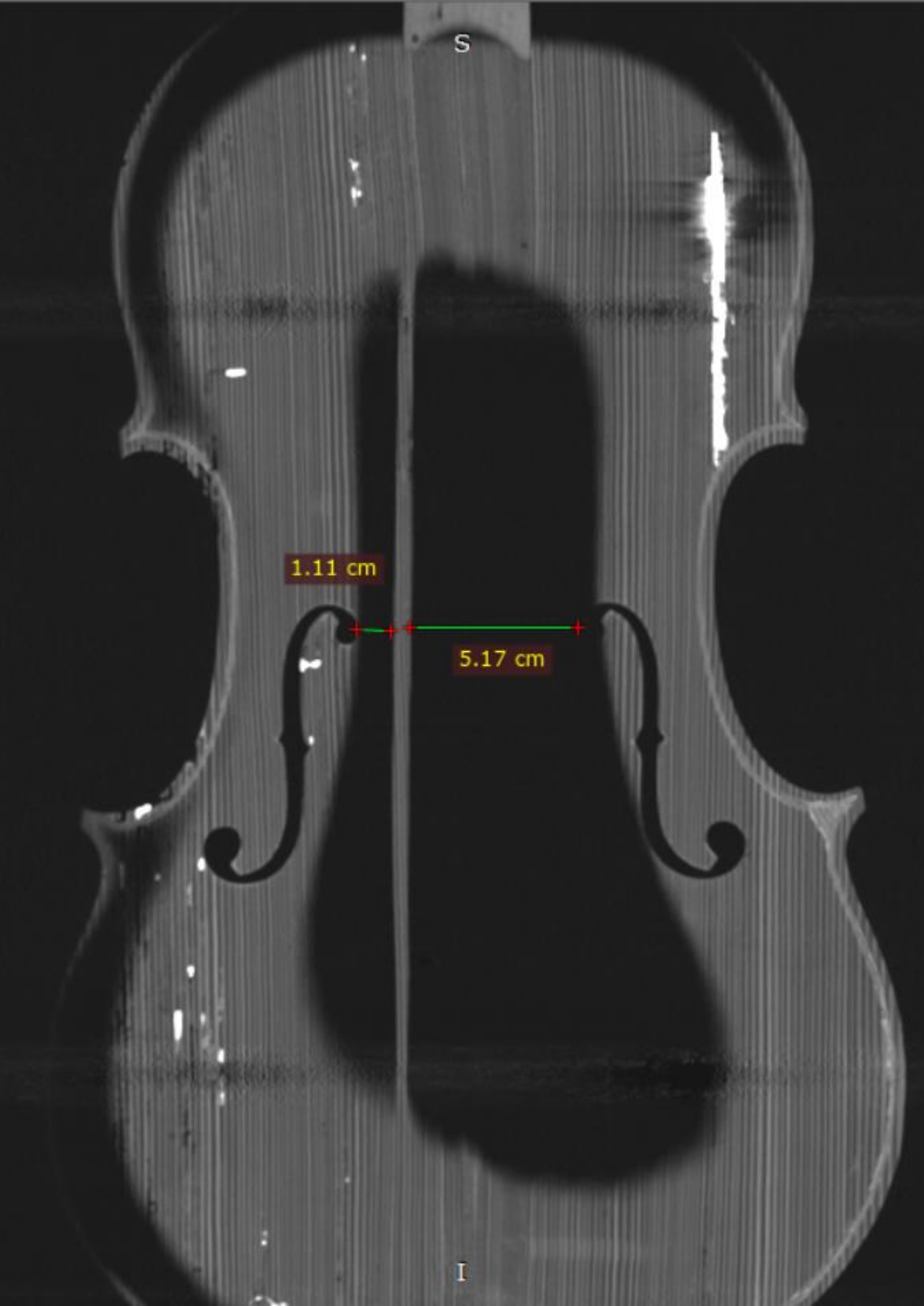



VIOLON MIM 01 - 4/05/2019 10:08:57 - ABDOMEN, iDose (4)

Im: 1012/1634  
Se: 202

A

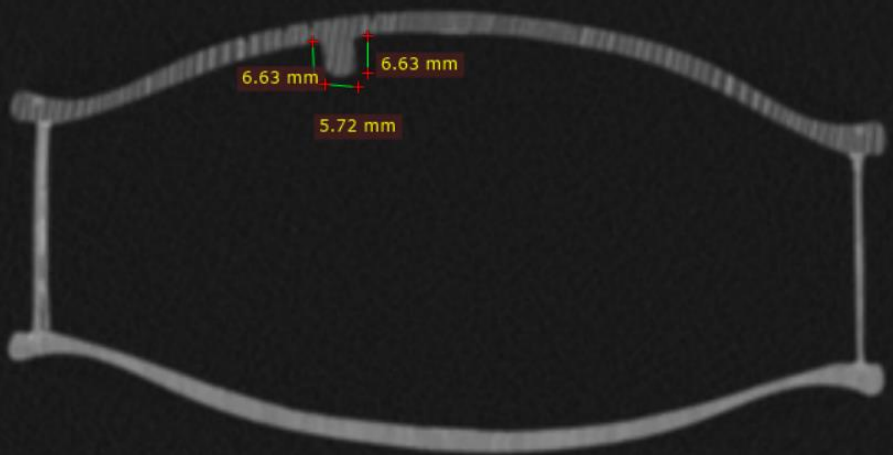

R

L

VIOLON MIM 01  
2836  
4/05/2019 O  
UCL St LUC  
8824  
Violon  
ABDOMEN, iDose (4)  
ABDOMEN

WL: -400 WW: 1500 [CT Lungs]  
T: 0.9mm L: 276.5mm

P

17mA 140kV  
4/05/2019 10:08:57

