

On the development of timber structures based on 3D interactive vector-based graphic statics (VGS)

Jean-Philippe JASIENSKI¹, Denis ZASTAVNI¹, Sylvain RASNEUR¹

Abstract. The present contribution addresses the topic of how to design novel structures in timber with the aid of a computational tool based on vector-based graphic statics (VGS) in a research-by-design approach. The context, scope and theoretical framework allowing to design strut-and-tie models in timber is explained. An application (design task given to Eng. Arch. students) is presented. The results concern the primary structure and joints, and are discussed regarding the initial objectives.

Keywords: Timber Construction, Structural Design, Digital fabrication, Parametric Design, Graphic-statics, VGS, Research-by-design, Teaching of structures.

1 Context and scope

Abstract. The first chapter explains how the latest developments of graphic statics combined with the use of timber can help tackling the issue of the design of low embodied carbon load bearing structures in the coming years.

1.1 The design of structures as a multi-factorial problem

The design of structures is a multi-factorial exercise that requires a permanent anchoring in the physical context of the project. In addition to ensuring the

¹ Jean-Philippe Jasienski (✉)

SST/LAB – Louvain research institute for Landscape, Architecture, Built environment
UCLouvain [LOCI] - Faculty of Architecture, Architectural engineering and Urbanism
Place du Levant 1 (L5.05.02) - B 1348 Louvain-la-Neuve (Belgium)

e-mail: jean-philippe.jasienski@uclouvain.be

mechanical resistance of the structure, the design needs to consider many different factors such as functionality, geometry, construction, cost, and environmental impact among others. In a world of limited and dwindling resources, the structure should also be designed with a view to disassembly, recycling, and reuse of its components.

A structural solution is only optimal regarding to the order of importance given to each criteria. The first challenge lies in defining this weighting. Architects are used to dealing with project involving a set of complex and different constraints. Structural relevance is often left aside in this case unless it reveals unavoidable in the definition of the project. The methodology presented here aims to give a simultaneous focus on both the structural and architectural requirements.

1.2 Graphic statics and the design of structures

1.2.1 Development of graphic statics

Regarding the design and analysis of structures, graphic statics has proven its considerable potential for achieving efficient and elegant structures. This method relies on two interdependent diagrams, namely the form and force diagrams (Maxwell, 1864). The first represent the geometry of the structure together with its external force, the latter embeds a synthetic vector representation of the forces applied to each node of the structure, thus representing vectorially the equilibrium of forces acting on the structures.

The interdependency of the two diagrams and their visual convenience provides a visual and intuitive understanding of the relationship between a structural shape and its inner stresses. Graphic statics was initially developed by the likes of Stevin (1586), Varignon (1687), Rankine (1858), Maxwell (1864), Culmann (1866), and Cremona (1872) among others. The swiss engineer Robert Maillart is one of the pioneers using graphic statics to define innovative and efficient structures. An iconic example is the Salginatobel Bridge built in 1929 (Fivet and Zastavni, 2012) This method relying on hand-drawing was almost abandoned in the second half of the 20th century, in part, due to the development of computers and numerical tools.



Fig. 1 Salginatobel Bridge (1929) from Robert Maillart. Left: picture taken by D. Zastavni (2022). Right: graphic static drawing: with form diagram on the right.

1.2.2 Resurgence of the Interest of graphic statics

The resurgence of interest for graphic statics among engineers, architects and researchers in the last years can somehow be explained as follow.

Numerical analysis approaches are not the best for the early stage of design since their way of working relies more on an analytical process with structural models requiring various hypothesis to give a result, resulting in a lack of interactivity.

Secondly, the possibility to benefit from a computational framework to use graphic statics created a favourable context, since hand drawing can be very time consuming and cannot quickly generate or modify geometries for a project.

Finally, the latest theoretical and practical development of 3D graphic statics opened new possibilities in terms of complex 3-dimensional structural typologies. In this, two main methods were developed, namely the vector-based (D'acunto et. Al, 2019) and the polyhedral-based (Akbarzadeh, 2017; Lee, 2018). Both approaches have their own specificities and benefits.

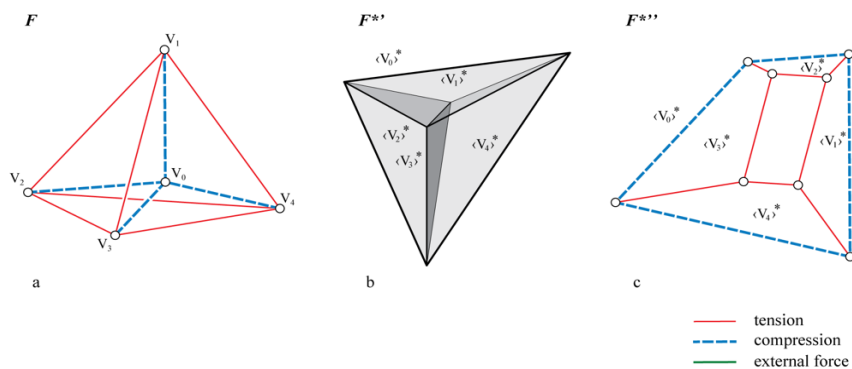

Fig. 2 Graphic statics in 3 dimensions: Form diagram F of a self-stressed tetrahedron (left), polyhedral based force diagram (b), vector-based force diagram (c) . (from D'acunto et al. 2019)

1.2.3 VGS a computational tool for vector based graphic statics

VGS is a plugin in the digital environment of Grasshopper from McNeel Rhinoceros whose main purpose is to automatically generate 3D vector-based interdependent form and force diagrams. VGS is developed by Pierluigi D'acunto, Jean-Philippe Jasienski, Yuchi Shen and Patrick Ole Ohlbrock. The theoretical foundations are based on vector-based graphic statics (D'acunto et al, 2019) and its implementation results in a computational tool (Jasienski et al., 2023)

The plugin allows the designer to generate 3D structures in equilibrium, as well as to modify them in real-time acting either on the force or the form diagram (while assessing the consequence of the modification on the other diagram). It is thus a

very adequate tool for the generation of efficient structures at equilibrium at the very first stages of the design phase.

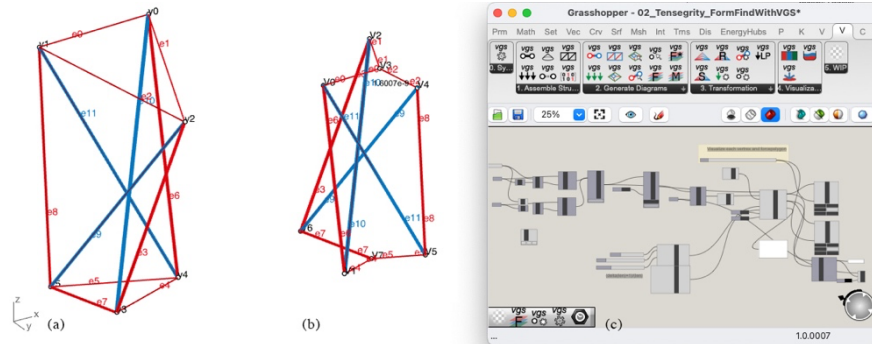

Fig. 3 View of a structural model of a 3D tensegrity structure in the VGS tool within the McNeel Rhinoceros and Grasshopper digital environment. From left to right: Form diagram (a), corresponding Force Diagram (b), parametric definition with the VGS modules in Grasshopper (c)

1.3 Timber as a construction material for the present and the future

The actual environmental crisis asks for a major reduction of our CO₂ emissions to limit the effects of global warming. In this context, structural engineers have an important role because the construction industry generates around 40% of gasses inducing GW and 36% waste in Europe. It is important to highlight that the primary structure of buildings represents more than 50% of this impact. In order to follow the goals fixed by the 2015 Paris agreement, the construction industry needs to be carbon-free for 2050. Combined to that, the increase in population calls for building new homes. Both engineers and architects are facing a huge challenge to find new ways of building that have a way better ecological impact.

In this context, timber appears to be a very interesting material because it has the capacity to store CO₂ and so is considered as having a positive carbon footprint compared to other materials. The negative GWP from the CO₂ point of view of timber calls it to play a major role as a construction material in the coming years. In this perspective, VGS being specifically designed to address structures mainly composed of bars in structural networks fits particularly timber structures that are characterized by such arrangements.

2 Theoretical framework

Abstract. The second chapter discusses the theoretical framework in which the research takes place. It introduces the hypothesis behind the use of graphic statics and strut-and-tie models for timber, within the framework of the theory of plasticity and more precisely the lower bound theorem.

2.1 Theory of plasticity

Until the 20th century, the only approach that was used for the calculation of structure was the theory of elasticity. The concept was firstly introduced by Galilée with the famous example of a cantilevered beam, where he considered the section as uniformly in tension (which is partially incorrect).

At the beginning of the 20th century, the first analysis of results of experiments on steel structures questioned that theory. Gvosdev formalized the first principle of plastic calculation in 1938. His work remained unknown, the first theory of plasticity as we know it today were established by Greenberg and Prager in 1949 under the name of static and kinematic theorems.

The theory of plasticity brings an answer to the inconsistencies of elastic theory, considering the ductility of the material and its consequences on the redistribution of stresses (Baker, 1959).

2.2 Lower bound theorem

Both theorem of plastic design were theorized in 1936 by Gvosdev and Feinberg, which Greenberg and Prager proved in 1949. The lower bound theorem, particularly suited for design purposes, says: for an ideal plastic material, any limiting load obtained from a distribution of internal forces is less than or equal to the actual limiting load.

As a result, a graphic statics drawing is one possible solution to the static theorem; equilibrium-based design was born, allowing for the management of different materials, structural typologies, or scales, while respecting the three initial conditions of the plastic static theorem. Robert Maillart's work on detailing his structures can be considered as application of this theorem.

2.3 Plastic design and STM approaches

Thanks to the lower-bound theorem of plasticity, any continuous structural system made of a plastic material can be modeled as a strut-and-tie network. The strut-and-tie modelling (STM) approaches were developed for the analysis of shear-walls and structural details in concrete structures based on plastic theorems.

Modelling the structural behavior of complex structures by strut-and-tie networks is a common practice in structural engineering when Bernoulli hypothesis does not apply, which has been effectively evidenced by several contemporary structural engineers.

Strut-and-tie models are considered by Fivet (2013) as high-level structural abstractions that depict the force path acting inside a structure in the most reduced way. It is composed only of rods in compression - struts - or traction - ties - linking together pin-jointed nodes on which point forces are applied. They can be used as generic abstractions for many types of structures such as pin-jointed frameworks or beams and frames subjected to bending moments, but also to trace lines of thrust in compression-only structures.

2.4 Characterisation and applicability of STM for timber

Plastic principles are used for structural dimensioning of timber in most structural standards. Stress-strain relationship of timber demonstrates clearly plastic capacities in compression, both parallel and perpendicular to fibres. In contrast, timber is fragile against traction forces, particularly perpendicular to fibres, with a resistance below one twentieth of the tensile strength along fibres. In most structures, the required ductility for using the principles of plastic analysis and design is reached through the plastic capacities of timber in compression and the ductility brought by steel components of joints.

Due to limited properties to redistribute force in tension, timber should be given special attention for contact joints alone when modeling it using struts and ties to avoid possible.

In this regard CLT panels, which are composed of several interlocking layers (three, five or seven) of planks placed side by side present some interest. These changes in direction within the material give them stiffness and resistance comparable in both main directions of the plane and enable using the principles of Strut-and-Tie Modelling in the framework of plastic design .

The topic of the design project is an addition to the Queen Elisabeth Music Chapel (located in Waterloo, Brussels), a center of excellence for artistic training with an international dimension and outreach. Its instruction is reserved for highly skilled musicians. At the time of its creation, the famous critic Vuillermoz already described it as a kind of 'modern Villa Medici'.

The students involved in the exercise are asked to design, in the vicinity of the existing buildings, a medium-sized rehearsal and concert hall and three to four pavilions for hosting artists in residence (all in timber structure).

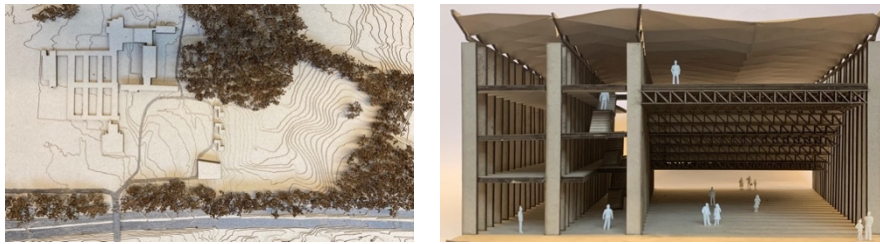

Fig. 5 View of the work of group 02: site model and model of the concert hall.

3.2 Research objectives

The structure of the main hall must be integrated into the design process by the groups of students from the beginning. Their task is to design, size, and draw their wooden structure: (1) design the structure to support vertical forces - dead loads, live loads -, horizontal forces - wind - in X and Y directions ; (2) model the structure on the principle of strut-and-tie modeling ; (3) build this model in the Rhino and Grasshopper environment and analyze it with VGS ; (4) detail a specific joint of the structure, assuming the sections are cut to transmit maximum forces through direct contact, while avoiding the use of steel fasteners. The joint is designed to make it possible to transfer forces according to their nature (tension/compression): contact planes, possible anchoring of tensile forces, possible assembly of the joint, restoration of continuity of one or more bars, etc. The purpose is to promote the direct transmission of forces between timber elements, in the direction of the fibers. The cuts for the assembly can be made using digital fabrication : cutting or milling.

Students involved in the design exercise have the option to work either with wooden sections or CLT panels, considering the possibility of modeling their structural working with STM.

3.3 Results

The design and development of the structure progress together through drawings, assessments, and models (see figure 5). Various support systems are studied to sustain roofs and facades while withstanding snow and wind loads. The large span is dimensioned based on the necessary capacity and architectural constraints. All or part of the structure is modeled using struts and ties in the parametric environment of Rhino and Grasshopper, allowing for continuous adaptation of the structure.

Here, designers ensure the static equilibrium of their structure by using form-finding tools such as Combinatorial Equilibrium Modeling (CEM) or others approaches. The structure is analyzed using VGS, with its transformation module to refine the structure according to the goals defined by groups of two, such as minimal efforts, minimal sections, required height, specific acoustic shape, or particular zenithal openings, etc. This process of analysis and optimization converges towards the definition of the shape and efforts of the structure. These assumptions are then used to design a joint to be manufactured using digital fabrication (see figure 6).

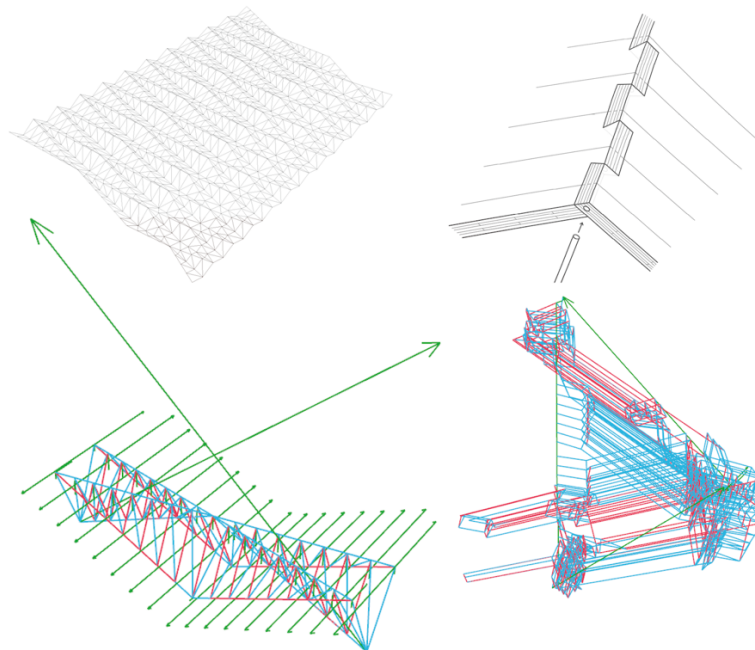

Fig. 7 Synoptic of the final results of group 06 - from top left to bottom right: structural model, assembly proposal, form diagram, force diagram

The diversity of structural models reflects the different approaches taken by the students in defining at the same time the architectural and structural project as a whole.

A few groups managed the exercise with three-dimensional strut-and-tie modeling. With the help of CEM (Ohlbrock and D'acunto, 2021), they were able to achieve a balanced structure despite the complex geometries (See figure 8).

The VGS tool allowed for a comparative analysis of the values of forces in the bars of the STM models. This can be done node by node using the vector-based approach of VGS: "Regarding the strut-and-tie network as a form diagram F , the equilibrium of the inner forces within the structure can then be solved iteratively node-by-node using vector-based 3D graphic statics (see figure 8).

Based on this graphic statics diagrams, timber joints can be designed according to applied forces (see figure 9). A critical examination of students' assemblies quickly revealed numerous pitfalls, such as managing different loading cases, inadequate bearing surfaces, insufficiently balanced forces, the use of metal fasteners for ductile failure in tension, excessively weakened sections due to notches or facet orientations in relation to the forces, etc... revealing the complexity of such an exercise.

Generally, the designed assemblies involve mechanisms that quickly lead to failure. For example, in the case of the support of the beam of group 04 (see figure 10): if a moment caused the beam to rotate around its support, the tie and the column in tension could cause brittle failure. Conversely, the tie in tension and compression in the column would pull the tie out of the column and also cause failure.

These examples highlight the benefits of a rigorous methodology to design timber-to-timber contact assemblies, with the advantage of using three-dimensional structural models designed and analyzed by the VGS tool.

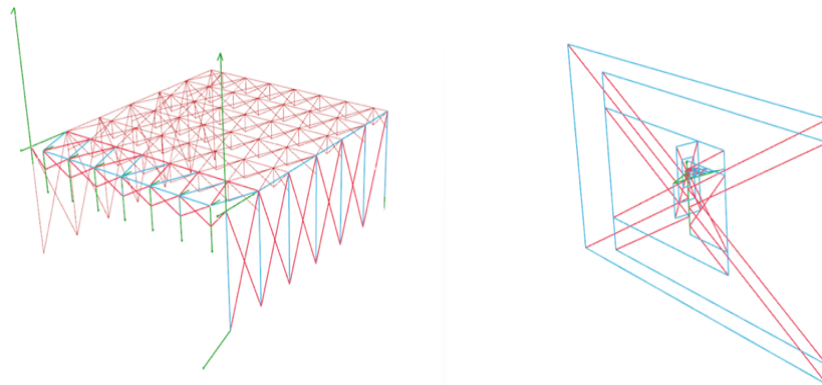

Fig. 8a: Form diagram (left) and forces diagram (right) of the primary structure

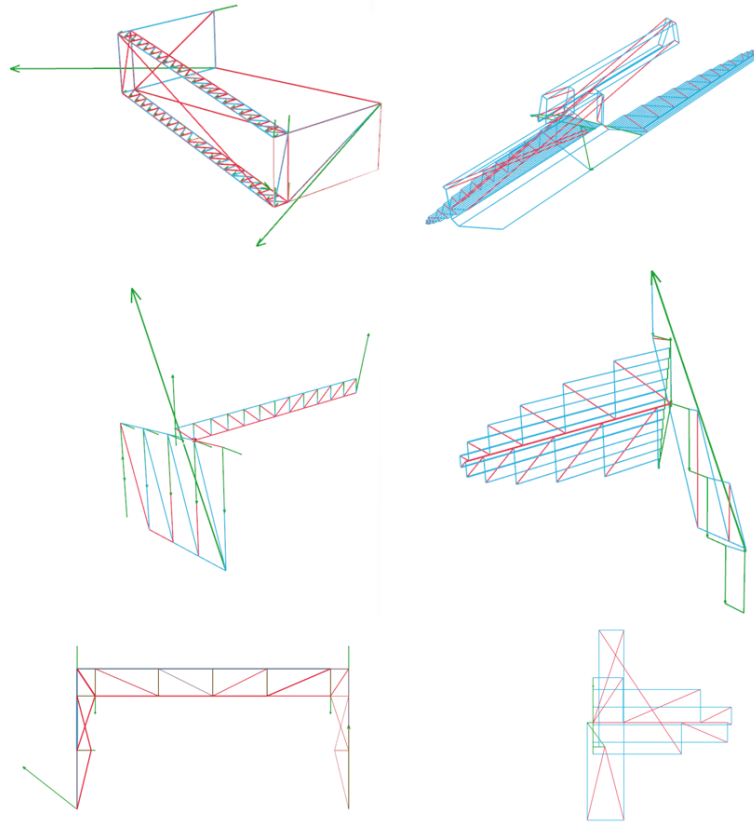

Fig. 8b Form diagram (left) and forces diagram (right) of the primary structure – Each line represents a project

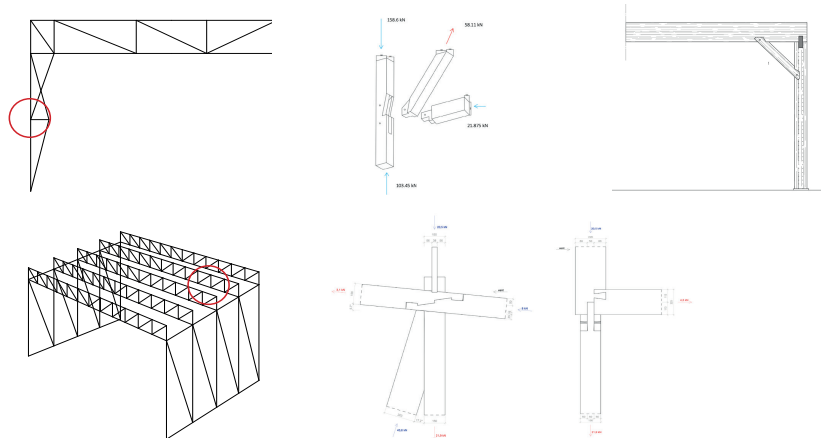

Fig. 9a: Structural model (left) and timber-to-timer joint (right).

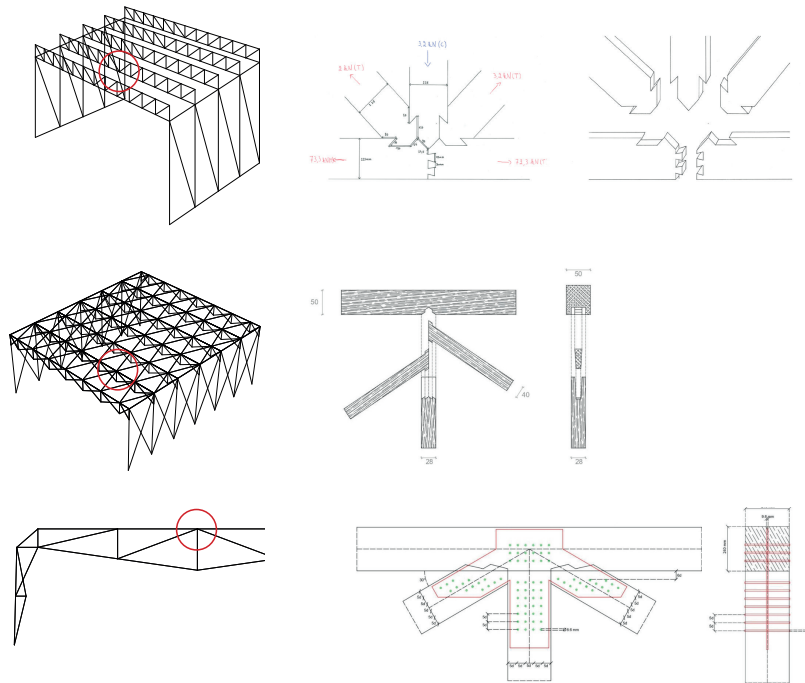

Fig. 9b Structural model (left) and timber-to-timber joint (right). Each line represents a project.

4 Discussions and future work

The paper proposed a research-by-design workflow for the design of innovative and structurally efficient timber structures and timber-timber joints. The methodology was applied to a case study as a multi-factorial design task for a group of 3rd year Engineer Architect students. Even if they didn't meet all of the initial objectives, the resulting designs nevertheless demonstrate the interest of the proposed workflow. Designing these joints with graphic statics and the VGS tool allows for the optimization of the amount of material needed to manufacture a connection under design-specific conditions.

Because of the difficulty to visually represent these complex connections and the forces involved, a node-by-node approach, with superimposing form and force diagrams, is not always sufficient for a fine understanding of the working of assemblies. In future design session, using a representation of contact surfaces would allow to go beyond intuition for a better control of stress trajectories and failure mechanisms.

Considering robotic manufacturing potential of these connections for further work opens up new geometrical possibilities and allows for the elimination of any constraints that may be associated with traditional manufacturing methods.

The parametric nature of the VGS approach in a multi-factorial design project workflow demonstrated his interest for timber design challenges. Based on an adequate representation of the connections and an iterative use of VGS, the organization of future design session would allow a more precise development of timber-to-timber connections for the development of wooden structures.

5 References

1. Akbarzadeh, M. (2017), 3D graphic statics using polyhedral reciprocal diagrams, PhD thesis, ETH Zurich, Department of Architecture
2. Baker, J. F., Horne, M. R., and Heyman, J. (1956). *The Steel Skeleton, vol. 2: Plastic Behavior and Design*. Cambridge University Press, New York.
3. Cremona, L. (1867) Corso di statica grafica, Regio Istituto Tecnico Superiore, Milano
4. Culmann, C. (1866) Die graphische Statik, Zürich: Meyer und Zeller.
5. D'Acunto P., Jasienski J.-P., Ohlbrock P.O., Fivet C., Schwartz J. and Zastavni D. (2019) International Journal of Solids and Structures 167 (2019) 58–70
6. Fivet C. (2013) Constraint-Based Graphic Statics, a geometrical support for computer-aided structural equilibrium design. PhD Thesis, UCLouvain
7. Fivet, C. & Zastavni D.. (2012) The Salginatobel Bridge design process by Robert Maillart (1929). Journal of the IASS 2012, 53(1): 39-48.
8. Hodge, P. G. J. (1959). *Plastic analysis of structures*. McGraw-Hill Book Company ??? check this. Otherwise, use Jacques Heyman as a ref. (Structural Analysis: A Historical Approach Broché – 18 octobre 2007)
9. Jasienski J-P., Shen Y., Ohlbrock P.O., Zastavni D. and D'Acunto P. (2023) A computational implementation of Vector-based 3D Graphic Statics (VGS) for interactive and real-time structural design, Computer-Aided Design 2023 (under review)
10. Lee J. Computational (2018) Design Framework for 3D Graphic Statics, PhD thesis, ETH Zurich, Department of Architecture
11. Maxwell, J. C. On reciprocal figures and diagrams of forces. Philosophical Magazine 27-n°4: 250-261, 1864.
12. Nejur A., Akbarzadeh M. (2021), PolyFrame, Efficient Computation for 3D Graphic Statics, Computer-Aided Design, Volume 134, 2021, 103003, ISSN 0010-4485,
13. Ohlbrock, P.O. and D'acunto, P. (2020) A Computer-Aided Approach to Equilibrium Design Based on Graphic Statics and Combinatorial Variations, Computer-Aided Design 121, 2020.
14. Rankine. (1858) A manual of applied mechanics, R. Griffin, London, 1858
15. Stevin S. (1586) De Beghinselen der Weeghconst [The Principles of the Art of Weighing]. Leyden: Christoffel Plantijn; 1586.
16. Tanadini D, Schwartz J. (2021) Analysis and design of timber-to-timber connections based on the lower bound theorem of the theory of plasticity, proceedings of WCTE 2021
17. Van Mele, T., Block, P (2014) Algebraic Graph Statics. Computer-Aided Design 53, 104–116.
18. Varignon P. (1687) Projet d'une nouvelle mécanique: avec un Examen de l'opinion de M. Borelli, sur les propriétés des Poids suspendus par des cordes., Paris, Chez la Veuve d'Edme Martin, Jean Boudot, & Estienne Marti
19. Zastavni, D. (2008) La conception chez Robert Maillart, Morphogenèse des structures architecturales, PhD Thesis, Université Catholique de Louvain, 2008.