

Optimization of the Paris wastewater treatment plants and sewer network: preliminary results

Cassandre Tasiaux* Denis Dochain* Joshua Taylor**
Alain Rapaport*** Peter Vanrolleghem****

* ICTEAM, UCLouvain, 4-6 avenue Georges Lemaître, 1348
Louvain-la-Neuve, Belgium (e-mail:
cassandretasiaux@gmail.com, denis.dochain@uclouvain.be).

** New Jersey Institute of Technology, USA (e-mail:
taylor.a.josh@gmail.com)

*** INRAE, 2 place Viala, 34060, Montpellier Cedex 01, France,
(e-mail: alain.rapaport@inrae.fr)

**** Université Laval, Québec, Canada (e-mail:
peter.vanrolleghem@gci.ulaval.ca)

Abstract: This paper deals with the application of second order cone convex optimization to the real time management of the wastewater treatment plants and sewer network of Paris and of its suburbs. It presents preliminary results applied on a simple case study composed of (simple) validated models of three wastewater treatment plants (Seine Aval (SAV), Seine Centre (SEC) and Seine Grésillons (SEG)) and their (inter)connections to the sewer network modelled by transport delays.

Keywords: Convex optimization, second order cone, network control, wastewater treatment, real time management.

1. INTRODUCTION

Wastewater treatment has been and is still a major societal issue for several decades, addressing the treatment of both industrial and domestic wastewater. Domestic wastewater is basically treated via biological means, and there are three main biological wastewater treatment processes: activated sludge, anaerobic digestion, and lagoons, e.g. Dochain and Vanrolleghem (2001), Dochain et al (2003). Activated sludge is the most largely used process to treat municipal wastewater. In the city of Paris and its suburbs there are six wastewater treatment plants using basically activated sludge, all being connected to the sewer network that collects the wastewater from the whole region (see Figure 1). Two important features are important to be mentioned when considering the wastewater treatment of Paris and of its suburbs:

- (1) First of all, one specific feature of the Seine river is its flow rate as compared to the wastewater flow rate of Paris and of its suburbs; in particular the flow rates of wastewater and that of the Seine river are of the same order of magnitude during the summer;
- (2) In presence of extreme events (like heavy rains or storms), some wastewater treatment plants may reach saturation for the wastewater treatment, which can lead to the non-treatment of part of the wastewater which is released to the Seine river (by-pass). Indeed what may be typically happening during these extreme events is that the total wastewater flow rates to be treated increase while their concentration de-

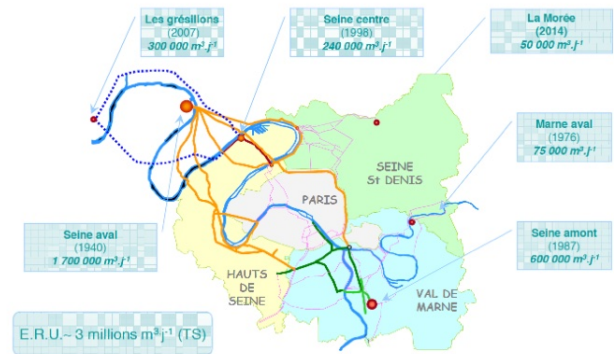

Fig. 1. The wastewater treatment plants and sewer network (magenta) of Paris and of its suburbs

creases (see Figures 3 and 4 below as a matter of illustration). But the degradation rates of the activated sludge (biomass) used to reduce the wastewater has its own time constants, typically larger (slower) than those of the hydraulic retention times during these events. This may explain the increase of non-treated wastewater that may push their concentrations above the norms.

The European legislation (EU directives 91/271 and 98/15) has first concentrated on the need of having appropriate plants to treat wastewater mainly from domestic use to guarantee water quality, and of having well defined water quality norms to guarantee water quality to evalu-

ate water quality at the output of wastewater treatment plants. The first one concentrated only on norms on carbon removal (via measurements of COD (chemical oxygen demand) and BOD (biological oxygen demand)) while the second one extends the norms to nitrogen and phosphorus contents. The Water Directive (European commission (2000)) introduces an important change of paradigm by considering river basins (including underground water, for instance) in the water quality evaluation and treatment.

In this context, the need for integrated wastewater treatment at a large level appears to be a key issue, and in particular (in the context of Paris and of its suburbs) in presence of extreme events. In other words, the issue is: how can we guarantee that the water in the Seine river will meet the European norms everywhere and at all times?

The objective of the present research activity is to develop methodologies able to optimize the wastewater treatment at a larger scale (typically here, for Paris and its suburbs) by considering the optimal distribution among the different treatment plants of the wastewater coming from the sewer network.

So far, if many papers have been dedicated to the control of wastewater treatment processes (WWTP's), still a limited number of works have concentrated on integrated control of wastewater treatment networks. These include in particular the work of Vanrollegem and coworkers (Vanrollegem et al (2005)). More prominently, Puig and coworkers have been dealing with the integrated control of the wastewater treatment of the city of Barcelona in Catalunya, Spain, where Model Predictive Control (MPC) is used to optimize the on-line operation of the whole network of wastewater treatment plants and sewer network (Cembrano et al (2004), Puig et al (2009), Ocampo et al (2013), Sun et al (2020)). Robles and coworkers have also developed an MPC-based on-line management strategy for the Paris network (Robles et al (2019)), or more precisely on three WWTP's (Seine Aval, Seine Centre and Seine Grésillons), that has served with many respect as a basis for the present study.

Here another approach is considered, based on second-order cone convex optimization methods, developed in particular in the context of biological systems in general (Taylor and Rapaport (2021)). The present paper provides the preliminary results developed in the final year work (engineering graduation thesis) of C. Tasiaux (Tasiaux (2023)), based on a rather simple case study that combines the interconnection of three WWTP's (Seine Aval (SAV), Seine Centre (SEC) and Seine Grésillons (SEG)) and the sewer network. The dynamics of the three WWTP's are represented by mass balance equations of each plant considered as continuous stirred tank reactors (CSTR's) identified from real-life data gathered on each plant over a period of time of four years (Robles et al (2018)). Besides the dynamics of the sewer are modelled by time delays.

The paper is organized as follows. Section 2 presents the case study including the dynamical model of the WWTP's and of the sewer network. Section 3 introduces the basic concepts of second order cone convex optimization and its application to our case study. And Section 4 provides the preliminary optimization results that have been gathered in the thesis of C. Tasiaux (Tasiaux (2023)).

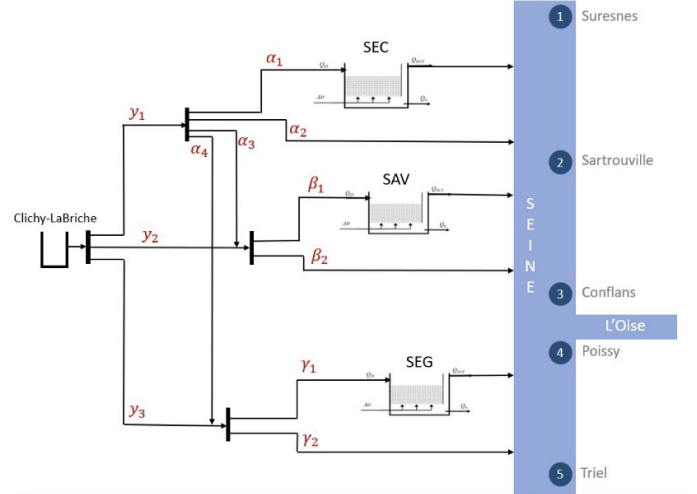

Fig. 2. Schematic view of the case study with the three WWTP's

2. THE CASE STUDY

The case study that has been studied here is schematically represented in Figure 2. y_1 , y_2 and y_3 represent the fraction of the total inlet wastewater flow rate at Clichy-LaBriche sent to the three WWTP's under study, i.e. Seine Centre (SEC), Seine Aval (SAV) and Seine Grésillons (SEG). α_i , β_i , γ_i ($i = 1$ to 2) are the distribution (in percentage) of the inlet flow rates to each WWTP that either enter the plants or bypass the plants. α_i ($i = 3, 4$) are the wastewater flow rates that are deviated from Seine Centre (SEC) to the two other plants.

The dynamics of the network are modelled as follows. For the purpose of our study (in order to reduce the complexity of the optimization approach implementation while keeping the key features of the dynamics of the plants), the wastewater treatment plants are considered as continuous stirred tank reactors (CSTR's). Their dynamics are represented by mass balance equations for carbon reduction and denitrification with the following components: BOD_5 (biological oxygen demand) for carbon removal, and NH_4 , NO_2 , NO_3 (ammonia, nitrite, and nitrate concentrations, respectively) for the denitrification process. This gives the following set of differential equations (see Robles et al (2018)):

$$\frac{dBOD_5}{dt} = \frac{Q_{in}}{V} BOD_{5,in} - \frac{Q_{out} + Q_w}{V} BOD_5 - \mu_1 X \quad (1)$$

$$\frac{dNH_4}{dt} = \frac{Q_{in}}{V} NH_{4,in} - \frac{Q_{out} + Q_w}{V} NH_4 - \mu_2 X \quad (2)$$

$$\frac{dNO_2}{dt} = \frac{Q_{in}}{V} NO_{2,in} - \frac{Q_{out} + Q_w}{V} NO_2 - \mu_3 X + \frac{1}{Y_{NH_4/NO_2}} \mu_2 X \quad (3)$$

$$\frac{dNO_3}{dt} = \frac{Q_{in}}{V} NO_{3,in} - \frac{Q_{out} + Q_w}{V} NO_3 - \mu_4 X + \frac{1}{Y_{NO_2/NO_3}} \mu_3 X \quad (4)$$

In the above equations, Q_{in} , Q_{out} and Q_w represent the inlet, outlet and waste flow rates (m^3/d), respectively. μ_i (i

= 1 to 4) are the specific growth rates for carbon removal (μ_1) and the three reactions involved in the denitrification process (μ_1, μ_2, μ_3)(in simple words, denitrification consists of the conversion of nitrogen under its different forms (ammonia, nitrite and nitrate) to its gaseous form N_2). Each specific growth rate is represented by a Monod equation:

$$\mu_1 = \mu_{1,max} \frac{BOD_5}{K_{BOD_5} + BOD_5} \quad (5)$$

$$\mu_2 = \mu_{2,max} \frac{NH_4}{K_{NH_4} + NH_4} \quad (6)$$

$$\mu_3 = \mu_{3,max} \frac{NO_2}{K_{NO_2} + NO_2} \quad (7)$$

$$\mu_4 = \mu_{4,max} \frac{NO_3}{K_{NO_3} + NO_3} \quad (8)$$

with $\mu_{i,max}$, $i = 1$ to 4 the maximum specific growth rates, and K_{BOD_5} , K_{NH_4} , K_{NO_2} , K_{NO_3} the saturation constants of the Monod model of each reaction.

Finally $\frac{1}{Y_{NH_4/NO_2}}$ and $\frac{1}{Y_{NO_2/NO_3}}$ represent the yield coefficients for the transformation of NH_4 into NO_2 , and of NO_2 into NO_3 , respectively.

In the present study, we have considered the biomass concentration X remains constant, which can be justified by the short periods of time considered for the optimization (typically a few weeks) during which it is fair to assume that the biomass does not change substantially (and therefore acts more as a catalyst than as an autocatalyst)(see e.g. Bastin & Dochain (1990)).

The parameters of the dynamical models of each WWTP's have been identified from four years of data (2009 to 2012)(and by considering, for the sake of simplicity, that $Q_w = 0.1Q_{in}$ (Robles et al (2018)). The 10 identified parameter values are given in Table 1.

Table 1. Identified values of the model parameters

Parameters	Units	SEC	SAV	SEG
$\mu_{1,max}$	1/day	3.99	2.56	1.93
$\mu_{2,max}$	1/day	0.84	0.83	0.89
$\mu_{3,max}$	1/day	1.68	1.27	0.92
$\mu_{4,max}$	1/day	1.21	1.38	0.85
K_{BOD_5}	mg/L	13.67	11.65	14.26
K_{NH_4}	mg/L	6.59	14.98	8.53
K_{NO_2}	mg/L	2.46	1.15	2.55
K_{NO_3}	mg/L	1.40	2.69	4.20
Y_{NH_4/NO_2}	-	0.28	0.25	0.27
Y_{NO_2/NO_3}	-	0.68	0.64	0.70

The flow rate from Clichy to the WWTP's and from Seine Centre to the other two WWTP's are simply modelled by transport delays, denoted d , computed from the ratio of the distance over the flow rate multiplied by the cross section of flow in the sewer. Mean values for the three scenarios (dry weather, rainy period, stormy period) have been considered and are summarized in Table 2.

3. SECOND ORDER CONE OPTIMIZATION

The optimization problem that is addressed can be basically formulated as follows:

Table 2. Transport delay values for the flow into the sewers (Distance (km), flow rate $Q_0(10^3 m^3/d)$, delay $d(min)$, Cl = Clichy)

Route	Dist	Dry		Rain		Storm	
		Q_0	d	Q_0	d	Q_0	d
Cl - SEC	4.82	216	128	306	90	306	90
Cl - SEC	13.26	1442	52	1351	56	1351	56
SEC-SAV	8.45	-	-	49	993	53	906
Cl - SEG	27.85	144	1125	144	1125	144	1125
SEC-SEG	23.27	-	-	98	1367	26	4993

$$\min_{T,S,y,\alpha,\beta,\gamma} \alpha_1 Q_{in,SEC} S_{SEC} \eta + \alpha_2 Q_{in,SEC} S_{in,SEC} \eta + \beta_1 Q_{in,SAV} S_{SAV} \eta + \beta_2 Q_{in,SAV} S_{in,SAV} \eta + \gamma_1 Q_{in,SEG} S_{SEG} \eta + \gamma_2 Q_{in,SEG} S_{in,SEG} \eta \quad (9)$$

under the constraints of the system dynamics (1-4, 5-8) and of the positivity of the state input variables (concentrations and flow rates are positive!).

In the above minimization formulation (9), y and S represent the vector of the fractions of the wastewater flow rate sent to the three WWTP's and the vector of the state variables, respectively:

$$y = \begin{pmatrix} y_1 \\ y_2 \\ y_3 \end{pmatrix}, S^T = \begin{pmatrix} BOD_5 \\ NH_4 \\ NO_2 \\ NO_3 \end{pmatrix} \quad (10)$$

while η is a weighting vector that allows to provide different weighting for each of the process components (BOD_5, NH_4, NO_2, NO_3)(its impact will be illustrated in Figure 8).

In the above formulation, we might be facing non-convexity issues, typically due to the growth rate terms. Indeed nonconvex optimization can be difficult even at small scales. Second-order cone programming (SOCP) is a tractable, convex optimization class that is often used to approximate nonconvex problems (Lobo et al (1998)). It happens that the Monod growth constraint is second order cone (SOC) under a constant biomass approximation. The variable T in (9) is used to convexify the optimization, by considering convex envelopes of (Tawarmalani and Sahinidis (2001)) to obtain an SOC outer approximation of the Monod growth constraint (Taylor and Rapaport (2021)).

In the present study, the dynamics are represented by discrete-time equations obtained by approximating the time derivatives of each state variables by a simple Euler discretization scheme (finite differences)(here, the sampling period has been chosen to be equal to 15 minutes).

Therefore the constraints of the optimization problem can now be written as follows:

$$T_i(t) \leq \begin{pmatrix} \mu_{1,max} \frac{BOD_5}{K_{BOD_5} + BOD_5} \\ \mu_{2,max} \frac{NH_4}{K_{NH_4} + NH_4} \\ \mu_{3,max} \frac{NO_2}{K_{NO_2} + NO_2} \\ \mu_{4,max} \frac{NO_3}{K_{NO_3} + NO_3} \end{pmatrix} \quad (11)$$

$$T_i(t) \geq T_{L_i}(t) + (T_{U_i}(t) - T_{L_i}(t)) \frac{S_i(t) - S_{m,i}(t)}{S_{M,i}(t) - S_{m,i}(t)} \quad (12)$$

$$V_{SEC}(S_{SEC}(t+1) - S_{SEC}(t)) = V_{SEC}\kappa_{SEC}T_{SEC}(t) - \alpha_1(t)Q_{in,SEC}S_{SEC}(t) + \alpha_1(t)Q_{in,SEC}S_{in,SEC}(t)$$

$$V_{SAV}(S_{SAV}(t+1) - S_{SAV}(t)) = V_{SAV}\kappa_{SAV}T_{SAV}(t) - \beta_1(t)Q_{in,SAV}S_{SAV}(t) + \beta_1(t)Q_{in,SAV}S_{in,SAV}(t) \quad (13)$$

$$V_{SEG}(S_{SEG}(t+1) - S_{SEG}(t)) = V_{SEG}\kappa_{SEG}T_{SEG}(t) - \gamma_1(t)Q_{in,SEG}S_{SEG}(t) + \gamma_1(t)Q_{in,SEG}S_{in,SEG}(t)$$

$$Q_{in,SEC}(t) = y_1(t - d_1)Q(t - d_1) \quad (14)$$

$$Q_{in,SAV}(t) = y_2(t - d_2)Q(t - d_2) + \alpha_3(t - d_3)Q_{in,SEC}(t - d_3) \quad (15)$$

$$Q_{in,SEG}(t) = y_3(t - d_4)Q(t - d_4) + \alpha_4(t - d_5)Q_{in,SEC}(t - d_5) \quad (16)$$

$$\sum_{l=1}^3 y_l(t) = \sum_{l=1}^4 \alpha_l(t) = \sum_{l=1}^2 \beta_l(t) = \sum_{l=1}^2 \gamma_l(t) = 1 \quad (17)$$

$$Q_{min,SEC} \leq \alpha_1(t)Q_{in,SEC}(t) \leq Q_{max,SEC} \quad (18)$$

$$Q_{min,SAV} \leq \beta_1(t)Q_{in,SAV}(t) \leq Q_{max,SAV} \quad (19)$$

$$Q_{min,SEG} \leq \gamma_1(t)Q_{in,SEG}(t) \leq Q_{max,SEG} \quad (20)$$

$$S(t), T(t) \geq 0 \quad (21)$$

$$y(t), \alpha(t), \beta(t), \gamma(t) \geq 0 \quad (22)$$

with $i \in [\text{SEC}, \text{SAV}, \text{SEG}]$.

The inequality (12) ensures that the approximation is close to the Monod growth rate, where $T_{L_i}(t)$ and $T_{U_i}(t)$ are defined as:

$$T_{L_i}(t) = \mu_{i,max} \frac{S_{m,i}X_i(t)}{K_i + S_{m,i}}, \quad T_{U_i}(t) = \mu_{i,max} \frac{S_{M,i}X_i(t)}{K_i + S_{M,i}} \quad (23)$$

with $S_{m,i} = [0, 0, 0, 0]$ and $S_{M,i} = [200, 50, 100, 150]$, $\forall i \in [\text{SEC}, \text{SAV}, \text{SEG}]$. These values define the lower and upper limits for the substrate concentrations (the values of $S_{M,i}$ have been defined from those collected via the measurements on the plants).

The 3 equations in (13) represents the dynamics in 3 WWTP's in discrete time. In these equations (13), κ represents the yield coefficient matrix (see Bastin & Dochain (1990)):

$$\kappa = \begin{pmatrix} -1 & 0 & 0 & 0 \\ 0 & -1 & 0 & 0 \\ 0 & \frac{1}{Y_{NH_4/NO_2}} & -1 & 0 \\ 0 & 0 & \frac{1}{Y_{NO_2/NO_3}} & -1 \end{pmatrix} \quad (24)$$

Inequality (11) is the convex relaxation on the growth constraint written as a SOC constraint (the reaction rates with the Monod model and constant biomass are concave).

The constraints (14)-(16) ensure the conservation of flow rates accounting for the delays d_1 from Clichy to SEC, d_2 from Clichy to SAV, d_3 from SEC to SAV, d_4 from Clichy to SEG, and d_5 from SEC to SEG (as computed in Table 2). The total inlet flow rate at Clichy is denoted as Q .

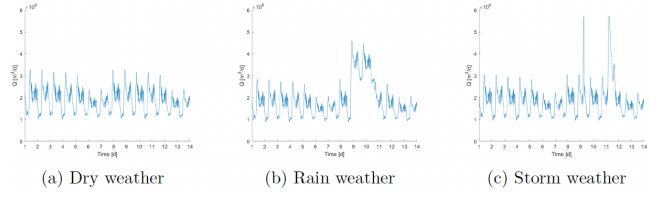

Fig. 3. Total inlet flow rate at Clichy for the three scenarios

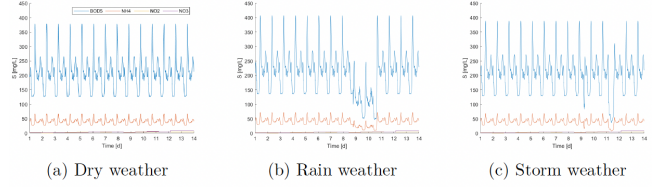

Fig. 4. Inlet substrate at Clichy for the three scenarios

4. SIMULATION RESULTS

The above optimisation procedure has been tested by considering (as mentioned above) 3 different scenarios over a period of two weeks: dry weather, rainy conditions, and stormy conditions. The input data files have been adapted (so as to fit the flow rates and inlet concentrations measured in the Paris network) from the COST action 682 benchmark that had been developed to test control strategies for WWTP's (Alex et al (2008)). The inlet flow rates and substrate concentrations at Clichy are presented in Figures 3 and 4.

It is important to recall that the main first objective is to address the behaviour of the wastewater treatment in presence of extreme events (heavy rains, storms) that typically last on rather short periods of time. This motivates the choice on rather short period of times for the simulation runs. This had also motivated the choice of constant biomass in the system dynamics over these short periods of time (see above, Section 2).

Figure 5 represents the reference case (dry weather) when no re-allocation of wastewater flow rates is required (no bypass). Figures 6 and 7 show the results of the optimization for rainy (two consecutive days of rain on days 9 and 10) and stormy weather conditions (where peaks of flow rates appears on days 9 and 11), respectively. Note that then in both scenarios, there are by-passes (blue curves) for the three WWTP's, and part of the wastewater flow rates are re-allocated from Seine Centre (SEC) to Seine Aval (SAV) (violet curve in the top left figures) and Seine Grésillons (SEG) (magenta curve in the top left figures) with higher re-allocation to Seine Grésillons than to Seine Aval for the rain scenario, and the other way round for the storm scenario.

Different weightings on the different substrates have been considered. This is illustrated in Figure 7 where higher weightings have been put on ammonia and nitrite (mainly) (which are some of the most sensitive pollutants to be reduced before being sent to the river). Figure 7 shows a clear improvement in the reduction of nitrite in the second case.

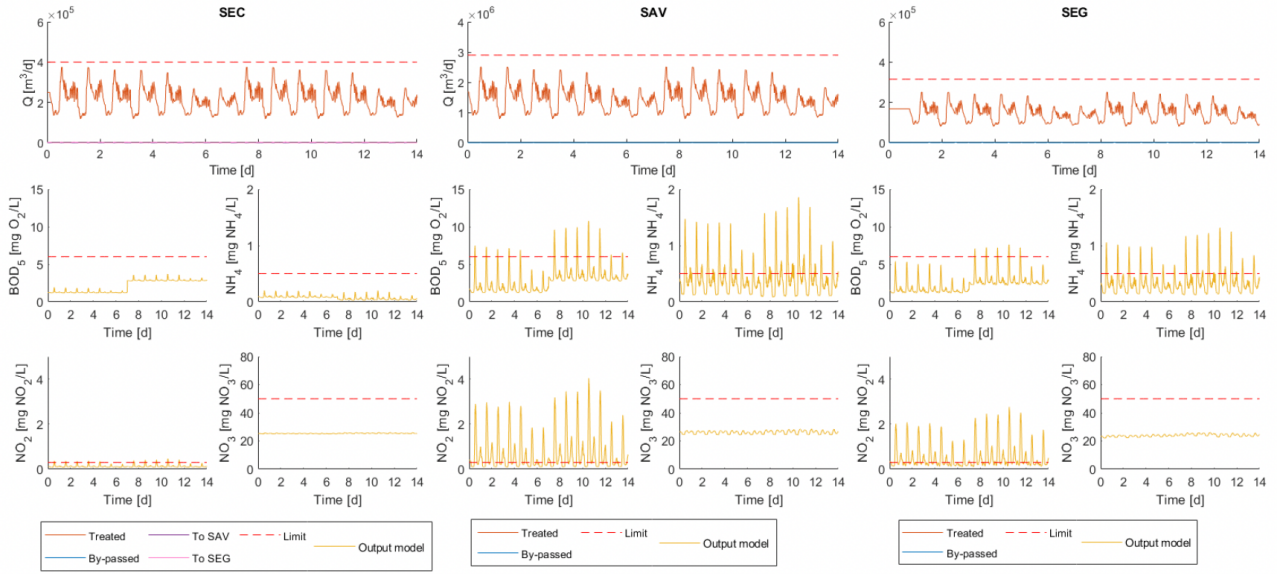

Fig. 5. Optimization results for dry weather conditions

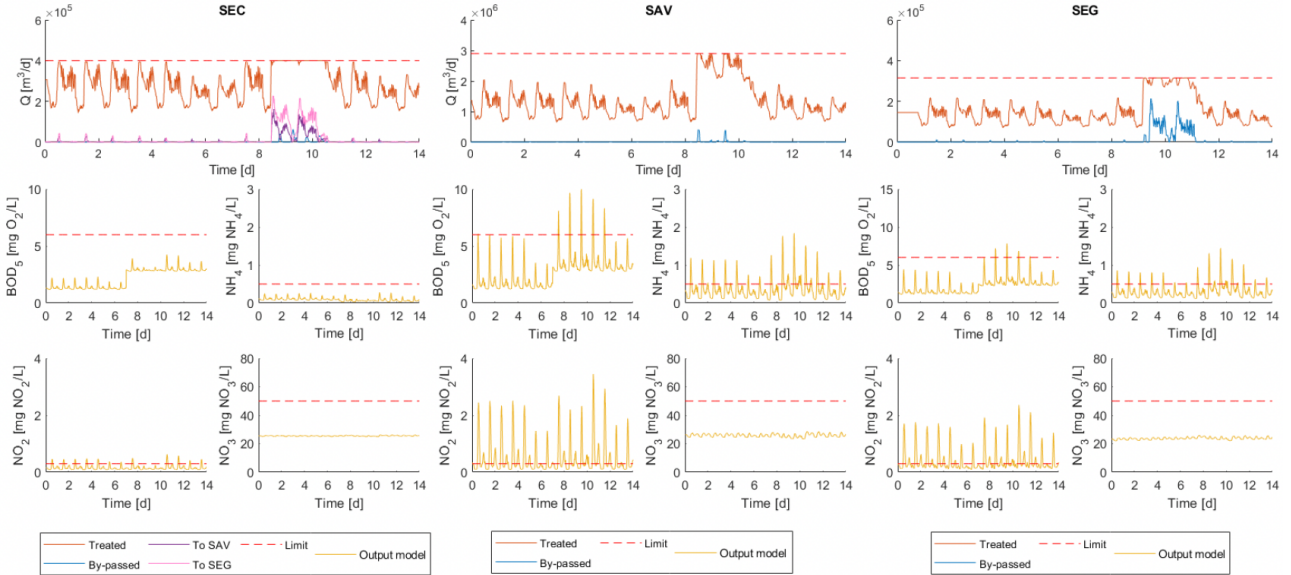

Fig. 6. Optimization results for rainy weather conditions

A general comment is that the norms seems often violated (even during the dry weather period). This is a side effect of the sampling period that has been chosen too small (15 minutes) with respect to the typical constants of the processes (hours-days), and the fact that the WWTP's have been modelled as perfectly mixed tanks (although in practice the treated wastewater spent substantial time within the plant between the time when it enters it and when it goes off. This should be the object of improvement in future research.

5. CONCLUSION

This paper has presented preliminary results of a real time management strategy of the wastewater treatment network (including sewers) of a case study of the city of Paris and of its suburbs. The management strategy is based on second order cone optimization concepts specif-

ically developed for the case study. The simulation results provide promising results, yet with room for improvement, e.g. when considering the discretization period of the optimization algorithm.

ACKNOWLEDGEMENTS

The authors would like to thank the research programme MOCOPEE (MODélisation Contrôle et Optimisation des Procédés d'Épuration des Eaux) for its technical and scientific support.

REFERENCES

- Alex J., L. Benedetti, J. B. Copp, K. V. Gernaey, U. Jeppsson, I. Nopens, M.-N. Pons, J. P. Steyerand P. A. Vanrolleghem (2008). Benchmark simulation model no.

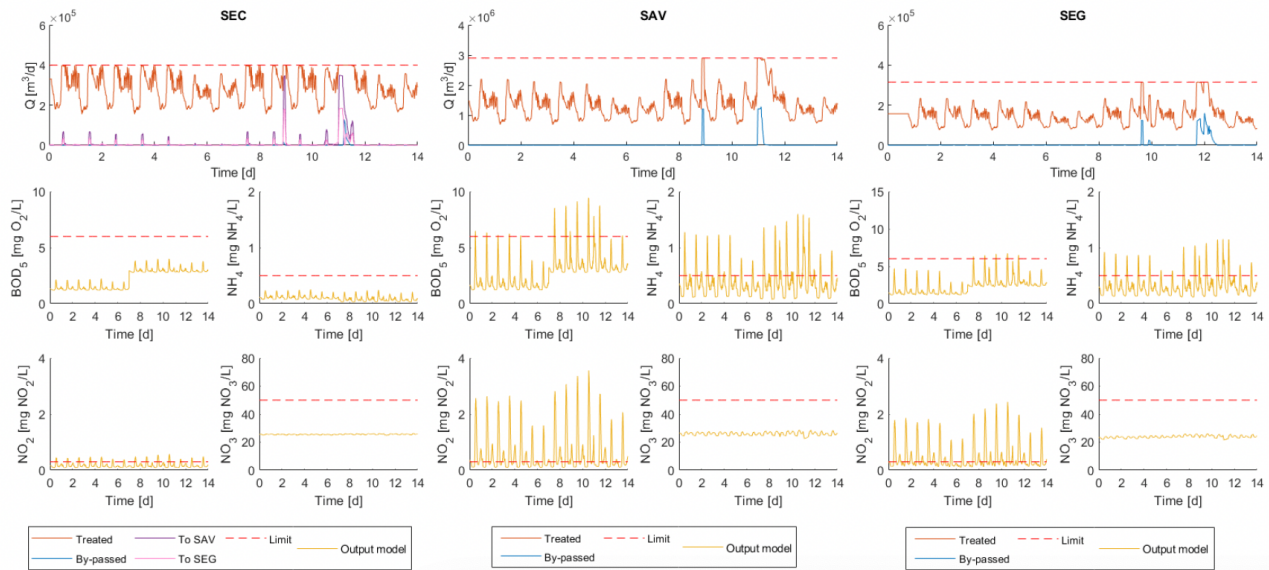

Fig. 7. Optimization results for stormy weather conditions

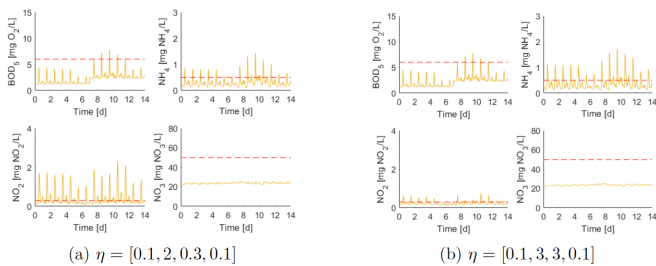

Fig. 8. Optimization results for different values of η

1 (bsm1), Report by the IWA Taskgroup on Benchmarking of Control Strategies for WWTPs, *The International Water Association*.

Bastin G. and D. Dochain (1990). *On-line Estimation and Adaptive Control of Bioreactors*. Elsevier, Amsterdam.

Cembrano G., J. Quevedo, M. Salamero, V. Puig, J. Figueras and J. Martic (2004). Optimal control of urban drainage systems. Acase study. *Control Engineering Practice*, 12, 1-9.

Dochain D., S. Gregoire, A. Pauss and M. Schaeffer (2003). Dynamical modelling of a waste stabilisation pond. *Bioprocess & Biosystems Engineering*, 26 (1), 19-26.

Dochain D. and P. Vanrolleghem (2001). Dynamical Modelling and Estimation in Wastewater Treatment Processes. *IWA Publishing, London*.

The EU Water Framework Directive - integrated river basin management for Europe.

Lobo M., L. Vandenberghe, S. Boyd and H. Leuret (1998). Applications of second-order cone programming, *Linear Algebra and its Applications*, 284, 193228.

Ocampo-Martinez C., V. Puig, G. Cembrano and J. Quevedo (2013). Application of predictive control strategies to the management of complex networks in the urban water cycle. *IEEE Control Systems Magazine*, 33(1), 15-41.

Puig V., G. Cembrano, J. Romera, J. Quevedo, B. Aznar, G. Ramon and J. Cabot (2009). Predictive optimal con-

trol of sewer networks using CORAL tool: application to Riera Blanca catchment in Barcelona. *Water Science and Technology*, 60 (4), 869-878.

Robles Rodriguez C.E., J. Bernier, V. Rocher and D. Dochain (2018). A simple model of wastewater treatment plants for managing the quality of the Seine River. *IFAC PapersOnLine*, 51(18), 880-885.

Robles Rodriguez C.E., A. Ben Ayed, J. Bernier, V. Rocher and D. Dochain (2019) Management of an integrated network of wastewater treatment plants for improving water quality in a river basin. *IFAC PapersOnLine*, 52(1), 358-363.

Sun C, L. Romero, B. Joseph-Duran, J. Meseguer, E. Munoz, R. Guasch, M. Martinez, V. Puig and G. Cembrano (2020). Integrated pollution-based real-time control of sanitation systems. *Journal of Environmental Management*, 269, 110798.

Tasiaux C. (2023). Real time optimization of a network of wastewater treatment plants. *Final year work*, UCLouvain, Belgium, <http://hdl.handle.net/2078.1/thesis:40631>.

Taylor J. and A. Rapaport (2021). Second-order cone optimization of the gradostat. *Computers and Chemical Engineering*, 151, 107347.

Taylor J., A. Rapaport and D. Dochain (2022). A sequential convex moving horizon estimator for bioprocesses. *Journal of Process Control*, 116, 19-24.

Taylor J., A. Rapaport and D. Dochain (2022). Convex optimization of bioprocesses. *IEEE Transactions on Automatic Control*, 67(9), 4932-4938.

Tawarmalani M. and N. Sahinidis (2001). Semidefinite relaxations of fractional programs via novel convexification techniques. *Journal of Global Optimization*, 20 (2), 33154.

Vanrolleghem P.A., L. Benedetti and J. Meirlaen (2005). Modelling and real-time control of the integrated urban wastewater system. *Environmental Modelling & Software*, 20(4), 427-442.