



Population pharmacokinetics and dosing simulations of total and unbound temocillin in the plasma and CSF of neurocritically ill patients with external ventricular drain-related cerebral ventriculitis

Perrin Ngougni Pokem^{1†}, Xin Liu^{2†}, Suzanne L. Parker ², Alexia Verroken³, Christine Collienne⁴, Patrice Finet⁵, Gert-Jan Wijnant¹, Pierre-François Laterre^{2‡}, Jason A. Roberts ^{2,6,7,8}, Françoise Van Bambeke ^{1*†} and Xavier Wittebole^{2†}

¹Pharmacologie cellulaire et moléculaire, Louvain Drug Research Institute, Université catholique de Louvain, Avenue E. Mounier 73/B1.73.05, B-1200, Brussels, Belgium; ²University of Queensland Centre for Clinical Research, Faculty of Medicine, The University of Queensland, Brisbane, Australia; ³Clinical Microbiology Department, Cliniques universitaires Saint-Luc, Université catholique de Louvain, Brussels, Belgium; ⁴Department of Critical Care Medicine, Cliniques universitaires St Luc, Université catholique de Louvain, Brussels, Belgium; ⁵Department of Neurosurgery, Cliniques universitaires St Luc, Université catholique de Louvain, Brussels, Belgium; ⁶Herston Infectious Diseases Institute (HeIDI), Metro North Health, Brisbane, Australia; ⁷Departments of Pharmacy and Intensive Care Medicine, Royal Brisbane and Women's Hospital, Brisbane, Australia; ⁸Division of Anaesthesiology Critical Care Emergency and Pain Medicine, Nîmes University Hospital, University of Montpellier, Nîmes, France

*Corresponding author. E-mail: francoise.vanbambeke@uclouvain.be

@VanBambekeUCL, @jasonroberts_pk, @GertJanWijnant

†Equal contribution as first or last authors.

‡Present address: Department of Critical Care Medicine, CHR Mons-Hainaut, Mons, Belgium.

Received 1 October 2023; accepted 12 December 2023

Background: Cerebral ventriculitis might be caused by Gram-negative bacteria, including ESBL producers. Temocillin may be a useful treatment option in this scenario; however, no consistent data are available regarding its penetration into the CSF.

Objectives: To describe the population pharmacokinetics of temocillin in plasma and CSF and to determine the probability for different simulated dosing regimens to achieve pharmacokinetic/pharmacodynamic (PK/PD) targets in the CSF.

Methods: Ten post-neurosurgical critically ill adult patients requiring continuous drainage of CSF were included in this monocentric, prospective, open-label, non-randomized study. They received 2 g loading dose temocillin over 30 min IV infusion, followed by a 6 g continuous infusion over 24 h. Total and unbound concentrations were measured in plasma ($n=88$ and 86) and CSF ($n=88$ and 88) samples and used to build a population PK model. Monte Carlo simulations were performed to estimate the PTA at 100% $C_{ss}>MIC$ (steady state concentration above the MIC) in CSF.

Results: All patients were infected with Enterobacterales with temocillin MICs ≤ 8 mg/L. The median (min-max) temocillin penetration in CSF was 12.1% (4.3-25.5) at steady state. Temocillin unbound plasma pharmacokinetics were best described by a one-compartment model. PTA for the applied dosing regimen was $>90\%$ for bacteria with MIC ≤ 4 mg/L.

Conclusions: The currently approved dose of 6 g by continuous infusion may be adequate for the treatment of ventriculitis by Enterobacterales with MIC ≤ 4 mg/L if considering 100% $C_{ss}>MIC$ as the PK/PD target to reach. Higher maintenance doses could help covering higher MICs, but their safety would need to be assessed.

Introduction

Temporary CSF drainage via an internalized shunt system or an external drainage in cases of acute increases of intracranial pressure is commonly used to treat patients with acute or chronic

hydrocephalus.^{1,2} Infection is the most common serious complication of these procedures.^{3,4} More specifically, ventriculitis incidence can reach 22% in patients with external ventricular drainage (EVD).^{3,5} These infections are associated with increased morbidity and mortality, drain revision, pain, neurological

deterioration, prolonged hospital stay and higher costs.⁶ Gram-negative bacteria represent 10%–20% of the incriminated germs.^{7,8} Meropenem is commonly used as empirical treatment in this clinical context, due to its adequate penetration into the CSF and broad spectrum of activity, including against ESBL-producing Gram-negative bacteria.^{6,9,10} Antibiotics with a more narrow spectrum would, however, be desirable to prevent resistance development.

Considered as a carbapenem-sparing drug, temocillin (6-methoxy-ticarclillin) is characterized by a spectrum covering Enterobacterales, including most ESBL producers.^{11,12} It is reported to minimally impact human intestinal microbiota.^{13,14} It is currently licensed for use in septicemia as well as in urinary tract, wound and lower respiratory tract infections caused by susceptible Enterobacterales.¹⁵ The role of temocillin as a therapeutic option for CNS infections is uncertain with a very few data available on its penetration into CSF, including those that are neurocritically ill. The only old available data report low concentrations (1–8 mg/L), close to the MIC of offending organisms after the administration of 2 g three times a day.¹⁶ The currently recommended dose for critically ill patients is 6 g/day divided in three administrations, with a susceptibility breakpoint set by EUCAST at 16 mg/L (restricted to complicated urinary tract infections).¹⁷ However, no pharmacokinetic/pharmacodynamic (PK/PD) evaluation has been performed to provide reassurance of the appropriate dosage.

For β -lactams, the time that unbound drug concentrations exceeds the MIC ($fT > MIC$) is the PK-PD index driving efficacy,¹⁸ even if the precise exposure target (from 1 to 4 \times MIC during 40% to 100% of the dosing interval) remains debated.¹⁹ For critically ill patients with high β -lactam PK variability, continuous infusion can help to improve PD target attainment and has been successfully applied for temocillin.²⁰ Of note, temocillin is one of the rare β -lactams to show a high protein binding (85% in healthy volunteers), which is saturable and dependent on the plasma albumin concentrations.²¹ In critically ill patients with cerebral ventriculitis, we previously showed that unbound fractions ranged from 32% to 52% for total plasma concentrations between 20 and 200 mg/L, possibly ensuring increased exposure compared with what would have been estimated based on unbound fractions determined for healthy volunteers.²¹ The effect of critical illness on temocillin protein binding is not well characterized.

The aims of this study were (i) to investigate and characterize the PK of total and unbound temocillin in plasma and CSF after administration of 6 g of temocillin by continuous infusion in neurocritically ill patients suspected of cerebral ventriculitis after EVD, and (ii) to build a population PK model and use it to perform Monte Carlo simulations to define optimized dosing regimens for these patients.

Materials and methods

Ethical approval

Ethical approval was obtained from the Comité d'Ethique Hospitalo-Facultaire of the Cliniques universitaires St-Luc; unique Belgian registration number B403201629439. Studies have been registered at EudraCT (number 2015-003457-18). A written consent was obtained from the patients or nearest relatives before inclusion.

Study design, patients and data collection

This prospective, monocentric, open-label and non-randomized PK study enrolled patients hospitalized in the ICU of the Cliniques universitaires St-Luc (Brussels, Belgium) and requiring EVD. Patients were included if ≥ 18 years old, diagnosed with or showing clinical signs of cerebral ventriculitis, and with CSF cultures positive for Enterobacterales with a temocillin MIC ≤ 8 mg/L. Patients were excluded if aged < 18 years, were potentially infected with a pathogen resistant to temocillin, allergic to any penicillin, or had participated in another experimental study with temocillin within 4 weeks, as well as pregnant or lactating women.

The following parameters were collected: demographics (age, sex, weight, BMI), treatment duration, daily CSF culture, with Gram strain and corresponding MIC, WBC count, severity scores (APACHE II and SOFA), C-reactive protein, medical history, biological and physiological parameters—plasma/CSF protein and albumin concentrations, CSF glucose and lactate concentrations, creatinine clearance [calculated as (urine creatinine \times 24 h urine volume/blood creatinine)/1440 min]—and hepatic enzymes (GGT, ALT and AST).

Antibiotic treatment

Temocillin was given as monotherapy for documented infections caused by susceptible pathogens or in combination in case of polymicrobial infection with bacteria resistant to temocillin (comedication selected based on their susceptibility profile). All patients received a temocillin loading dose (2 g) administered over 30 min in 50 mL of saline for injection, followed by continuous infusion over 24 h (6 g/day in 48 mL of water for injection infused at a rate of 2 mL/h) for up to 12 days.

Blood and CSF sample collection

Blood and CSF samples were taken at the end of the loading dose, and one or two samples were taken during each 24 h continuous dosing interval. Blood samples were drawn with an arterial catheter, collected in EDTA tubes and centrifuged for 15 min at 2000 g and 4°C. CSF samples were obtained via the EVD, and collected in dry tubes simultaneously with each blood sample whenever possible. All samples were stored at -80°C until analysis.

Analytical method

Chemicals and reagents

Temocillin was obtained from EUMEDICA S.A. (Manage, Belgium) as the branded product (NEGABAN) approved for parenteral human use in Belgium, the UK and France. Ticarcillin disodium (internal standard) was acquired from Sigma-Aldrich Corp. (St Louis, MO, USA); HPLC-grade methanol and acetonitrile were from J.T. Baker (Deventer, The Netherlands); formic acid and ammonium acetate were from Merck KgaA (Darmstadt, Germany).

Total and unbound temocillin determination

Total and unbound temocillin plasma and CSF concentrations were measured by an HPLC-MS/MS assay using ticarcillin as internal standard. Ultrafiltration was used to collect the unbound drug. The method was previously fully validated in plasma²² for both total and unbound concentrations and partially validated here in CSF (see [Supplementary method 1](#) for methodological details and Figure S1 and Tables S1 and S2 for validation data; available as [Supplementary data](#) at JAC Online), according to the FDA recommendations.²³

Plasma and CSF total protein and albumin content

Total proteins were measured by the biuret method,²⁴ and albumin by the bromocresol green dye method²⁵ using a Cobaz[®] analyser (Cobaz[®] 8000

Table 1. Characteristics of the study population

ID	Demographics				Biological and physiological parameters							Severity scores	
	Sex	Age (years)	Weight (kg)	BMI (kg/m ²)	CRP (mg/L) <5 ^a	CrCl (mL/min) >78 ^a	Plasma proteins (g/L) 64–83 ^a	Plasma albumin (g/L) 35–52 ^a	GGT (IU/L) <40 ^a	ALT (IU/L) 7–35 ^a	AST (IU/L) 13–35 ^a	SOFA score	APACHE II score
1	Female	56	75	25.9	131.0	129.0	63.0	38.0	315.0	150.0	94	2	21
2	Male	55	70	24.2	74.0	126.5	69.0	32.9	224.0	59.0	25	3	22
3	Male	58	80	26.2	24.9	110.0	70.8	32.6	41.0	19.0	9	1	15
4	Male	60	80	25.8	29.2	97.5	69.2	26.6	32.0	48.0	33	4	11
5	Female	54	65	23.8	98.9	132.5	68.3	24.8	244.0	235.0	221	3	17
6	Female	60	75	33.3	14.7	110.5	65.0	36.0	38.0	19.0	22	3	21
7	Female	59	90	31.1	123.7	66.0	60.0	40.2	52.0	17.0	32	3	14
8	Female	50	120	45.2	31.3	109.0	65.0	36.8	63.0	44.0	48	3	18
9	Male	20	80	26.1	53.2	153.0	60.8	34.8	72.0	48.0	18	0	5
10	Female	55	59	21.9	45.9	221.0	69.4	40.5	15.0	29.0	28	1	10
Median		55.5	77.5	26.0	49.6	118.5	66.7	35.4	57.5	46.0	30	3	16
Mean		52.7	79.4	28.4	62.7	125.5	66.1	34.3	109.6	66.8	53	2.3	15.4

CrCl, creatinine clearance based on a 24 h urine collection test; CRP, C-reactive protein; ID, patient identification.

^aReference value or range for this parameter.

series; Roche/Hitachi Cobas Systems Diagnostics, F. Hoffmann-La Roche Ltd, Basel, Switzerland).

Microorganisms and MIC determinations

Identification and antimicrobial drug susceptibility of the isolates were determined using automated systems of the clinical microbiology laboratory of the Cliniques Universitaires St-Luc (MALDI-TOF MS; Phoenix[®], Becton-Dickinson, Franklin Lakes, NJ, USA; and Etest[®], bioMérieux, Marcy-l'Etoile, France).

PK analysis

Plasma and CSF total and unbound temocillin concentrations were plotted against time, and the AUC at steady state was determined every day between the first and the last day of treatment using Equation 1:²⁶

$$\text{AUC} = C_{\text{ss}} \times \tau, \quad (1)$$

where C_{ss} is the temocillin concentration measured at steady state and τ is the dosing interval (24 h).

The other calculated parameters included the unbound fraction (UF) of temocillin (Equation 2), the penetration (PE) ratio²⁷ (Equation 3) and the proportion (PR) of total temocillin in CSF (Equation 4). The PR is a better estimate for the diffusibility of temocillin through the blood–brain barrier.

$$\text{UF}(\%) = 100 \times (C_{\text{unbound}}/C_{\text{total}}) \quad (2)$$

$$\text{PE}(\%) = 100 \times (\text{AUC}_{\text{total in CSF}}/\text{AUC}_{\text{total in plasma}}) \quad (3)$$

$$\text{PR}(\%) = 100 \times (\text{AUC}_{\text{total CSF}}/\text{AUC}_{\text{unbound in plasma}}) \quad (4)$$

Population PK modelling

Population PK analysis was performed using the non-linear mixed-effect modelling program Monolix version 2021R1 (LIXOFT, Antony, France)

implementing the stochastic approximation expectation maximization algorithm. The PK model was built to fit three types of data simultaneously: temocillin unbound and total plasma concentration and temocillin unbound concentration in CSF. The details about model development, covariate screening and model validation are presented in the [Supplementary material 1](#) and [Supplementary method 2](#).

Monte Carlo simulation assessment for different dosing regimens

Monte Carlo simulations were performed by Simulx 2021R1 based on the final PK model to generate 1000 profiles of total temocillin in plasma and temocillin in CSF for each candidate dosing regimen (see details in Results). The target was set as 100% $C_{\text{ss}} > \text{MIC}$ for temocillin concentration in CSF between 24 and 150 h after treatment. Peak concentrations for a loading dose of 6 g were also simulated. For each dosing regimen, the PTA was evaluated for MIC of 2, 4, 8 and 16 mg/L.

Statistical analysis

Statistical analyses of correlations between plasma and CSF concentrations were performed using version 4 of GraphPad software (GraphPad Prism Software, San Diego, CA, USA). Data were described as the mean \pm SD or the median (range). Statistical significance was defined as $P < 0.05$.

Results

Patient characteristics

Ten patients were included in the study. In total, 88 measured total plasma concentrations and 86 measured unbound plasma concentrations (two outliers discarded) together with 88 measured total/unbound CSF concentrations were used for model development. The demographics and baseline clinical characteristics of the patients are summarized in Table 1. All patients showed low

Table 2. Microbiological data, treatment characteristics and CSF analysis for individual patients

ID	Microbiological data		CSF analysis					Duration of temocillin treatment (days) ^{b,c}	
	Isolates	MIC (mg/L)	Proteins (mg/dL) 15–45 ^a	Albumin (mg/dL) <28 ^a	CSF/blood albumin ratio	Lactate (mmol/L) 1.1–2.4 ^a	WBC <5/μL ^a		Glucose (mg/dL) 40–80 ^a
1	<i>Klebsiella pneumoniae</i> ^{d,f}	4	4.30	2.60	0.068	2.30	143	70	7
	<i>Klebsiella oxytoca</i> ^e	2							
2	<i>K. pneumoniae</i> ^d	4	1.70	0.90	0.027	3.90	485	50	5
	<i>K. pneumoniae</i> ^e	4							
3	<i>Enterobacter cloacae</i> ^{d,g}	4	0.56	0.23	0.007	10.00	1945	18	7
4	<i>Escherichia coli</i> ^d	4	2.40	1.20	0.045	16.70	3620	3	7
5	<i>E. aerogenes</i> ^{d,f}	8	1.60	0.70	0.028	24.20	8504	3	4
6	<i>E. cloacae</i> ^{d,f}	8	8.60	4.50	0.125	20.20	2931	3	5
	<i>K. pneumoniae</i> ^e	4							
7	<i>K. pneumoniae</i> ^{d,f}	4	0.69	0.32	0.007	4.30	499	57	4
8	<i>E. cloacae</i> ^{d,g}	6	1.30	0.70	0.019	4.70	496	24	6
9	<i>E. cloacae</i> ^{d,g}	4	0.80	0.19	0.005	1.30	6	67	7
	<i>E. coli</i> ^e	8							
10	<i>E. cloacae</i> ^d	8	2.60	1.02	0.025	22.40	5894	3	13
Median			1.65	0.80	0.026	7.35	1222	21	7
Mean			2.46	1.24	0.036	11.00	2452	30	7

ID, patient identification.

^aReference value or range for this parameter.

^bAll patients received a 2 g loading dose followed by a daily dose of 6 g given by continuous infusion.

^cSee Table S3 for the whole antibiotic treatment received by the patients and the microbiological and clinical outcomes.

^dIsolate from CSF.

^eIsolate from blood.

^fESBL producer.

^gCephalosporinase producer.

SOFA and APACHE II severity scores. Median (range) plasma protein and albumin concentrations were 66.7 (60.0–70.8) and 35.4 (24.8–40.5) mg/L, respectively. Nine patients showed high (>78 mL/min) creatinine clearance, and a majority of them elevated hepatic enzymes in plasma. Microbiological data, treatment characteristics and CSF analysis for individual patients are presented in Table 2. Bacteria isolated in CSF had temocillin MICs of 4, 6 or 8 mg/L. The median (range) duration of temocillin treatment was 7 (4–13) days (see Table S3 for the global treatment of these patients). All patients had fever and CSF WBC count >5/μL before treatment. CSF protein and albumin concentrations ranged from 0.56 to 8.60 g/L and 0.23 to 4.50 g/L, respectively. CSF lactate was elevated (>2.4 mmol/L) in seven patients, and CSF glucose was low (<40 mg/dL) in six patients.

PK analysis

Individual data of plasma and CSF concentration profiles of temocillin are presented in Figure 1. Differences were observed among patients with respect to both the concentrations achieved in the plasma and in the CSF, and to the time needed to reach the steady state in CSF. In plasma, the median (min–max) total and unbound concentrations after the loading dose (2 g) administered over 30 min ($C_{30\text{min}}$) were 145.80

(126.80–166.30) mg/L and 51.11 (46.40–79.96) mg/L, respectively. During the continuous infusion (6 g/24 h), steady-state total and unbound median concentrations ($C_{24-168\text{h}}$) were 91.04 (60.08–129.80) mg/L and 29.05 (13.67–54.00) mg/L, respectively. The unbound median fraction was 29.05 (19.96–52.52)%.

In CSF, more than 6 h was needed to reach concentrations >8 mg/L (MIC of most infecting bacteria), with total and unbound CSF steady-state median concentrations ($C_{24-168\text{h}}$) of 11.18 (2.77–22.55) mg/L and 9.37 (2.60–20.50) mg/L.

The concentration of temocillin was measured after the end of the treatment by continuous infusion in five patients. After 12 h, the median (min–max) total and unbound concentrations in CSF were 6.08 (2.98–10.40) mg/L and 5.60 (2.01–8.10) mg/L, respectively.

The median (min–max) percentage of penetration of temocillin in the CSF was 0.99 (0.43–2.30)% 30 min after the loading dose and 12.07 (4.26–25.47)% at steady state, both with high inter- and intra-individual variability (Figure 2a). The proportion of temocillin in the CSF was also highly variable but much higher [median (min–max) = 36.7 (18.1–69.9)%]. A positive correlation was observed between the unbound concentration in plasma and in CSF (Figure 2b), as well as between total and unbound concentrations in CSF (Figure 2c). In this case, a linear regression with a slope close to 1 (0.907) was observed, indicating that the drug is

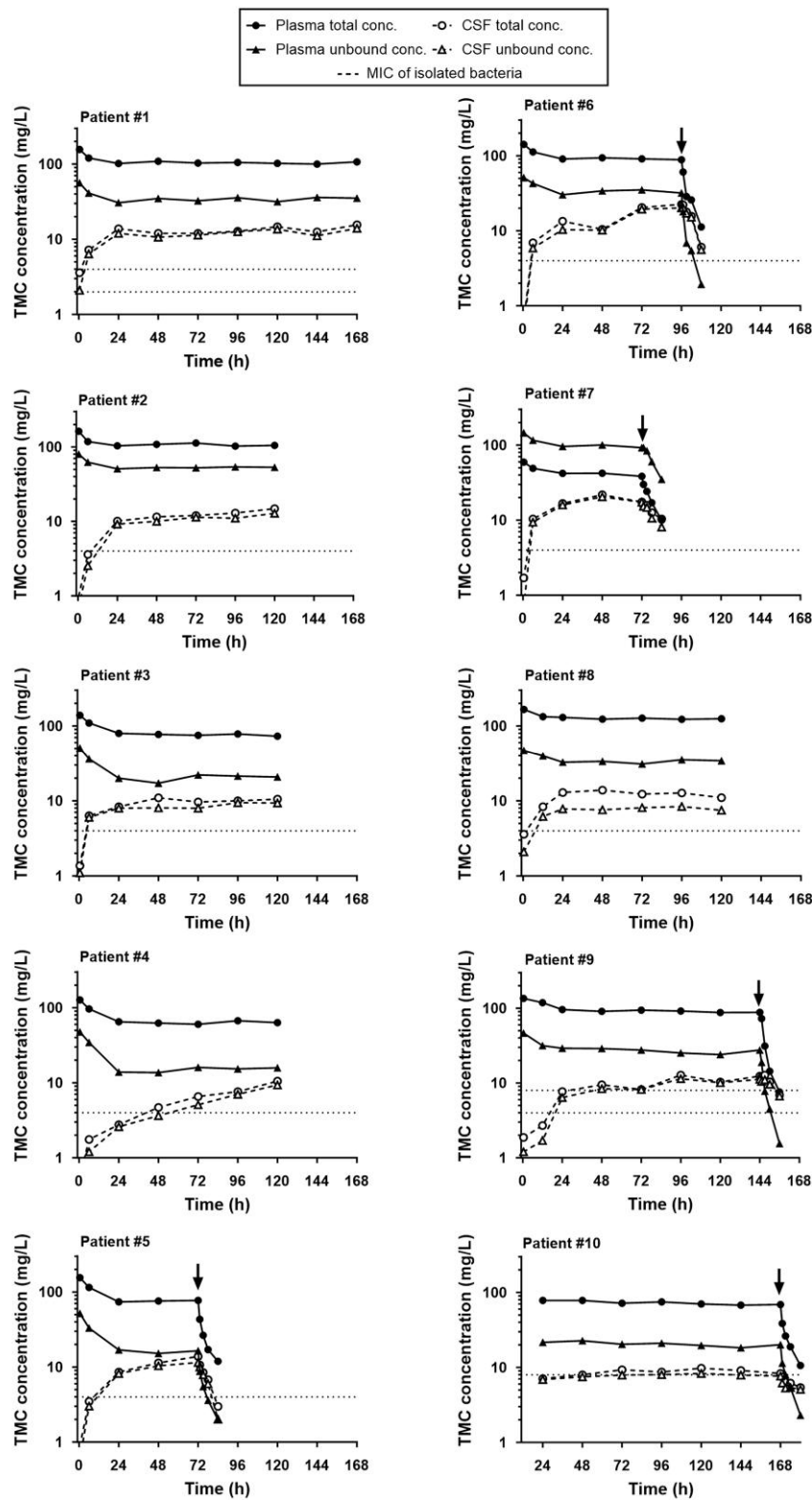

Figure 1. Individual profiles of temocillin total and unbound concentrations in the plasma and the CSF of patients. All patients received a loading dose (2 g) administered over 30 min followed by continuous infusion (6 g/day). The vertical arrow points to the time point at which the infusion was stopped in patients for whom the clearance of temocillin was followed. The dotted lines correspond to the MIC for the bacteria isolated in each patient. TMC, temocillin.

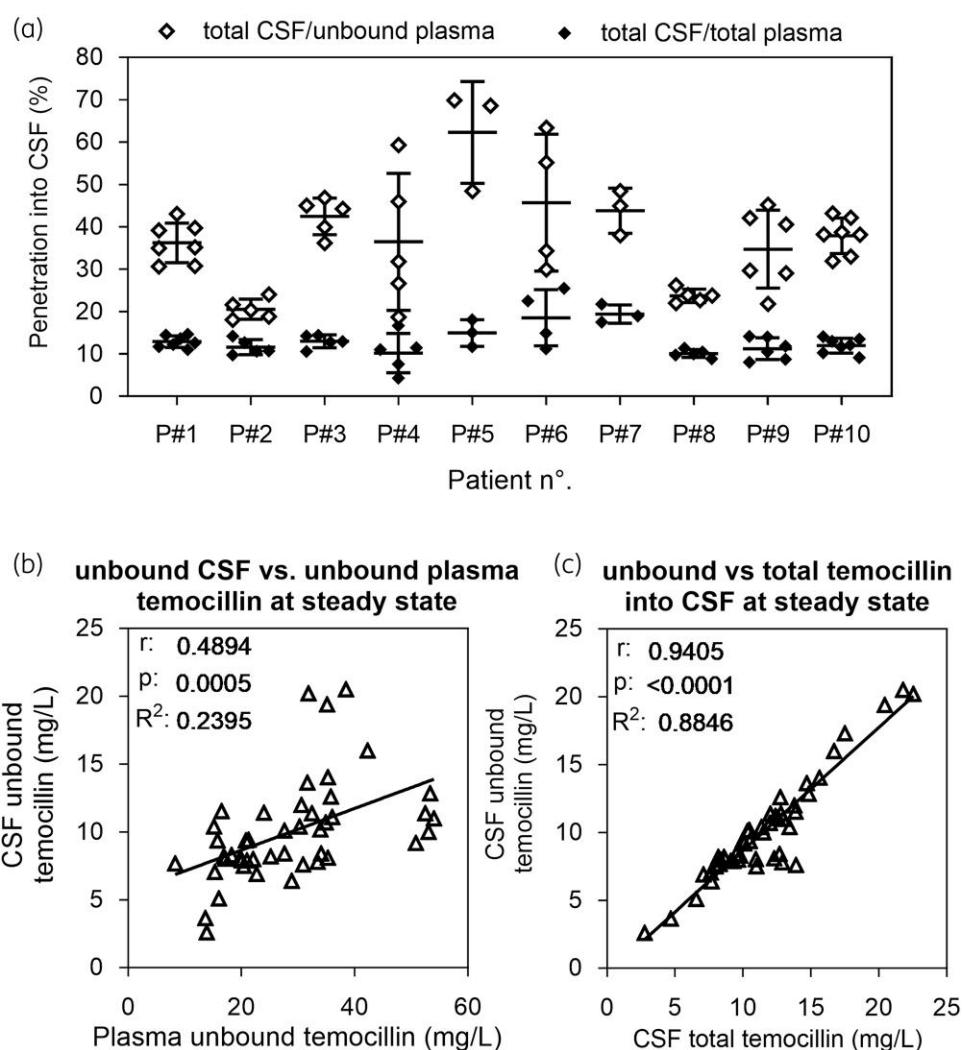

Figure 2. Temocillin penetration in CSF. (a) Individual data of penetration (total CSF/total plasma 24 h-AUC) and proportion (total CSF/unbound plasma 24 h-AUC) ratios at steady state. Each symbol corresponds to the AUC calculated for a 24 h interval, with the horizontal lines linked by a vertical line corresponding to the mean +/- SD. (b) Correlation between plasma unbound concentrations and CSF unbound concentrations. (c) Correlation between CSF total and unbound concentrations at steady state. Each symbol corresponds to a set of data at a specific time for a single patient. In (b) and (c) Pearson correlation coefficient (r) and P values of the correlation as well as R^2 of the linear regression are shown.

essentially unbound in this fluid [median unbound fraction of 89.64 (73.42–100.00%)] owing to the low protein concentration in CSF.

PK modelling

Temocillin unbound plasma concentration versus time profiles were best described by a one-compartment model with first-order elimination and first-order transferring to the CSF compartment. Building a two-compartment model and considering a back-transfer of temocillin from CSF to the central compartment did not improve the model fitting (no decrease in corrected Bayesian information criteria BICc; Table S4). The final structural model describing temocillin PK and its binding in plasma and CSF is illustrated in Figure 3. Inter-individual variability was estimated for

all parameters. Variability on association and dissociation constants k_{on} and k_{off} was included to take into consideration potential variability in availability of binding sites between individuals. Additive error model was selected to describe residual variability for unbound and total plasma concentrations, whereas combined error model (additive plus proportional error) was used to describe residual variability for CSF concentration.

Initial screening of the correlation between PK parameter estimates and covariates indicated that WBC count in CSF (CSF_WBC), APACHE II score, AST, and lactate in CSF (CSF_ACLAC) could be potential covariates. Based on the criteria (Table S4), only the effect of CSF_ACLAC (calculated weighted mean²⁸ in the population: 7.15 mmol/L) on transferring rate constant from the central compartment to the CSF compartment (k_{13}) was retained in the final model as

expressed as below:

$$k_{13i} = k_{13pop} \times \left(\frac{CSF_ACLAC_i}{7.15} \right)^{0.074} \times e^{n_{cl,i}}$$

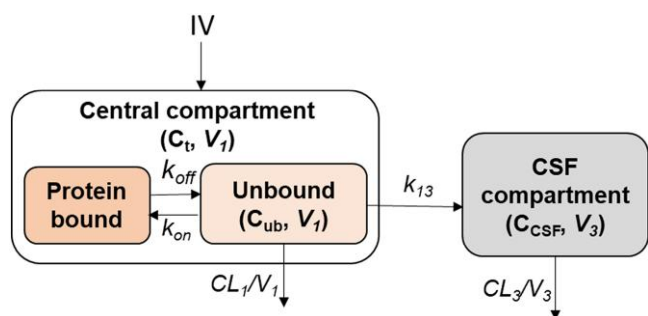

Figure 3. Schematic diagram of the final PK model for temocillin in the central compartment and in the CSF after IV infusion. C_{CSF} , CSF unbound concentration; C_t , concentration at instant t ; C_{ub} , plasma unbound concentration; CL_1 , plasma clearance; CL_3 , CSF clearance; k_{off} , first-order dissociation rate constant; k_{on} , second-order association rate constant; k_{13} , transferring rate constant from central to CSF compartment; V_1 , volume of distribution in the central compartment; V_3 , volume of distribution in CSF compartment. This figure appears in colour in the online version of JAC and in black and white in the print version of JAC.

PK parameters of the final Model I together with bootstrap results from 1000 successful runs are reported in Table 3. The goodness-of-fit (GOF) plots of the final models are presented in Figures S2 and S3, and the Visual Predictive Checks (VPC) plots, in Figure S4.

CSF penetration/uptake was estimated using individual values for AUC_{24h} predicted from the model. The median (min–max) percentage of penetration was 0.62 (0.31–0.82)% 30 min after the loading dose and 11.3 (10.5–17.4)% at steady-state, and the median (min–max) percentage of proportion was estimated to be 37.3 (27.6–49.0)%. These values are close to those calculated in the non-compartmental analysis.

Monte Carlo simulations

Nine temocillin dosing regimens were simulated (Table 4). Regimen #1 is the original dosing regimen used in the study. To evaluate the effects of lactate concentration in CSF, unbound CSF and total plasma concentrations of temocillin time profiles of patients with lactate concentration of 2, 10 and 20 mmol/L were simulated and are presented in Figures 4 and 5, respectively. Increased CSF lactate concentration led to higher unbound CSF concentrations of temocillin (Figure 6a), but had little effect on total plasma concentrations (Figure 6b). Increasing the loading dose to 6 g resulted in the median of the peak total plasma concentration exceeding 350 mg/L from 1000 simulations and

Table 3. Estimates of the population pharmacokinetic parameters

Parameter	Estimate (%RSE) [shrinkage %]	Bootstrap median (95% CI)
Fixed effects		
CL_1 (L/h)	8.43 (11.1)	8.52 (6.76–10.70)
V_1 (L)	13.3 (3.93)	13.3 (12.6–14.2)
k_{13} (h^{-1})	3.38×10^{-4} (4.77)	2.71×10^{-4} (2.10×10^{-4} to 3.63×10^{-4})
V_3 (L)	0.17 (23.5)	0.130 (0.089–0.200)
CL_3 (L/h)	0.012 (5.76)	0.0097 (0.0070–0.0130)
k_{on} (L/mg/h)	0.076 (14.5)	0.065 (0.040–0.102)
k_{off} (h^{-1})	9.02 (14.9)	7.58 (4.74–12.10)
Effect of CSF_ALAC on k_{13}	0.074 (41.1)	0.100 (0.001–0.264)
Random effects		
BSV_ CL_1 (%)	34.6 (22.9) [0.40]	33.2 (21.7–43.1)
BSV_ V_1 (%)	6.90 (48.0) [13.5]	6.50 (1.46–10.30)
BSV_ k_{13} (%)	4.69 (89.0) [29.0]	4.10 (1.19–15.10)
BSV_ V_3 (%)	70.3 (25.0) [19.0]	64.2 (28.3–102.0)
BSV_ CL_3 (%)	6.67 (93.3) [–32.3]	5.20 (1.33–13.00)
BSV_ k_{on} (%)	18.9 (63.5) [–6.05]	13.90 (1.98–33.40)
BSV_ k_{off} (%)	22.2 (49.6) [6.89]	16.50 (2.32–37.60)
Residual variability		
$a_{C_{ub}}$ (mg/L)	4.88 (8.45)	4.88 (3.74–5.84)
$a_{C_{total}}$ (mg/L)	12.4 (8.27)	12.40 (8.24–16.10)
$a_{C_{CSF}}$ (mg/L)	0.73 (23.3)	0.73 (0.16–1.41)
$b_{C_{CSF}}$ (mg/L)	0.10 (24.0)	0.0970 (0.0013–0.2100)

a , additive error; b , proportional error; BSV, between subject variability; C_{ub} , plasma unbound concentration; C_{total} , plasma total concentration; C_{CSF} , CSF unbound concentration; CL_1 , plasma clearance; CL_3 , CSF clearance; CSF_ALAC, lactic acid concentration in CSF; k_{off} , first-order dissociation rate constant; k_{on} , second-order association rate constant; k_{13} , transferring rate constant from central to CSF compartment; RSE, Relative Standard Errors; V_1 , volume of distribution in the central compartment; V_3 , volume of distribution in CSF compartment.

Table 4. Summary of PTA estimation based on a target of 100% $C_{ss>MIC}$ in the CSF for proposed dosing regimens maintaining temocillin total plasma concentrations <350 mg/L

CSF lactate concentration (mmol/L)	MIC (mg/L)	#1	#2	#3	#4	#5	#6	#7	#8	#9
2	2	LD: 2 g/0.5 h MD: 6 g/24 h	LD: 4 g/0.5 h MD: 6 g/24 h	LD: 2 g/0.5 h MD: 12 g/24 h	LD: 4 g/0.5 h MD: 12 g/24 h	LD: 2 g/0.5 h MD: 18 g/24 h	LD: 4 g/0.5 h MD: 18 g/24 h	LD: 4 g/0.5 h; ID: 2 g/1 h MD: 6 g/24 h	LD: 4 g/0.5 h; ID: 2 g/1 h MD: 12 g/24 h	LD: 4 g/0.5 h; ID: 2 g/1 h MD: 18 g/24 h
10	2	99.9^a	100	99.6	99.6	96	96	98.3	97.4	95.2
	4	93.4	97	99.5	99.5	96	96	96.8	97.4	95.2
	8	49.2	60.5	90.7	93.2	94.6	95	65.1	91.9	94.4
	16	3.7	6.1	43	49.7	71.4	76	6.2	51.2	76.4
	2	100	100	99.6	99.6	96	96	98.3	97.4	95.2
	4	96.2	98.8	99.5	99.6	96	96	97.8	97.4	95.2
	8	60.5	72.3	93.4	95.9	95.2	95.6	75.6	94.7	95
	16	6.5	10.2	53.8	60.9	79.5	82	11.4	61.8	82.3
20	2	100	100	99.6	99.6	96	96	98.3	97.4	95.2
	4	97.1	99.2	99.6	99.6	96	96	98	97.4	95.2
	8	64.8	76.9	94.7	96.9	95.4	95.8	80.6	95.3	95
	16	8.2	13.5	58.6	65.2	81.2	84.6	15.2	66	84.4

ID, intermediate dose; LD, loading dose; MD, maintenance dose.

^aValues in bold highlight dosing regimens for which the PTA is >90%.

was not considered in further simulations, as this was the highest concentration reached in a single patient in a previous study, for which no adverse reaction was observed²¹ (Figure 6b). Increasing the maintenance dose led to higher steady state concentrations in plasma and in CSF. Adding a 1 h infusion dose of 2 g after the loading dose slightly reduced the time needed to reach the steady state in CSF without marked influence on plasma concentrations.

Because the drug was administered by continuous infusion, PTA was assessed for 100% $C_{ss>MIC}$ with MIC set for 2, 4, 8 or 16 mg/L (Table 4). PTA (100% $C_{ss>MIC}$) for the original dosing regimen (#1) was >90% for bacteria with MICs ≤ 4 mg/L whatever the CSF lactate concentration. Increasing the loading dose to 4 g (regimen #2) would not improve PTA significantly whereas doubling the maintenance dose to 12 g (regimen #3) could reach PTA (100% $C_{ss>MIC}$) of 90% for MIC ≤ 8 mg/L whatever the CSF lactate concentration while maintaining total plasma concentration below 350 mg/L. Our simulation suggests that a PTA (100% $C_{ss>MIC}$) of 90% for MICs of 16 mg/L could not be reached even when combining increasing loading doses and maintenance doses (regimens #4–6), or when adding after the loading dose a 2 g infusion over 2 h in order to reach faster the steady-state concentration (regimens #7–9). Considering the time needed to reach the steady state, lower targets (40%–70% $fT>MIC$) could be reached for 90% of isolates with MICs of 16 mg/L with the highest dosing regimen proposed (#9), whatever the CSF lactate concentration (not shown).

Discussion

This study is to our knowledge the first to describe the plasma and CSF pharmacokinetics of temocillin administered by continuous infusion in neurocritically ill patients with cerebral ventriculitis and external ventricular drainage with the aim to optimize dosing strategies in this specific population.

As for other β-lactams, the penetration of temocillin into CSF is weak, which was anticipated based on its physicochemical properties (hydrophilic molecule doubly negatively charged at physiological pH, with high plasma protein binding).⁹ Lipophilicity is indeed a major characteristic of drugs that cross the blood–brain barrier by passive diffusion.²⁹ At steady state, the proportion of temocillin in the CSF is highly variable, due to differences in its binding to plasma proteins among patients,²¹ whereas its penetration rate (12%) is comparable to that previously reported for this drug (8%–15%),¹⁶ and in the range of those reported for other penicillins (6%–26%),^{30,31} cephalosporins (0.7%–26%)^{29,32–34} or carbapenems (1%–25%)^{35–37} in infected patients. As for other β-lactams,^{38,39} the penetration of temocillin in CSF is modest compared with that reported in other body fluids (peritoneal, vesicular, epithelial lining, ascitic fluids),^{40–43} where temocillin concentrations reach 40%–70% of those measured in the plasma. This can be easily explained by the structure and function of the blood–brain barrier, protecting the brain from invasion by potentially toxic molecules, like drugs.²⁹ Lower penetration values in CSF are also reported for β-lactams in non-infected patients^{33,44} as inflammation is well known to increase β-lactam diffusion in the CSF by opening tight junctions.⁴⁵

Population PK modelling of temocillin has been reported previously in intensive care patients^{20,40,43,46} and in

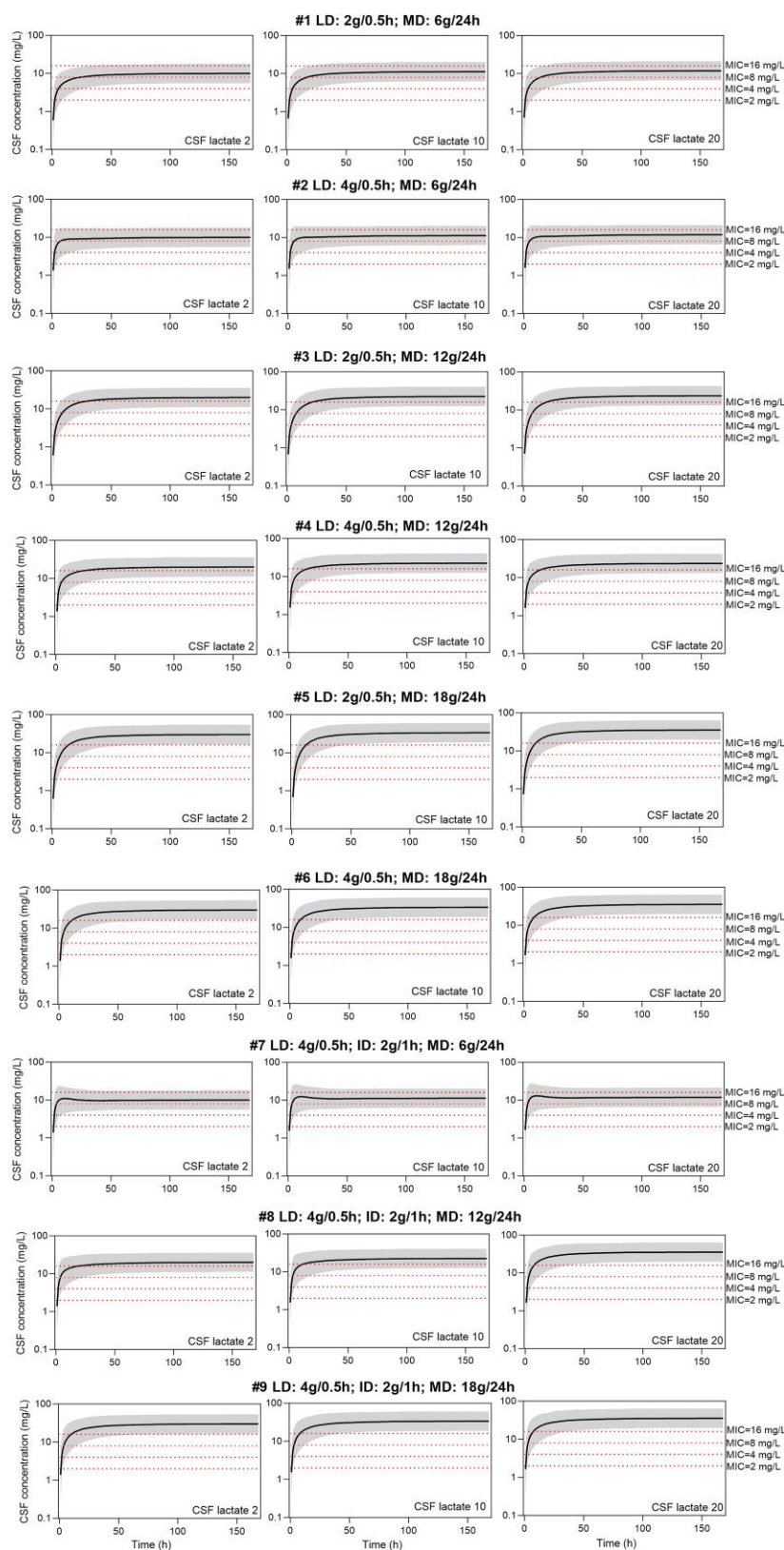

Figure 4. Simulated unbound CSF concentration-time profiles for temocillin when administered with different dosing regimens. The solid line represents the median of 1000 simulations, and the limits of the grey area represent the 5th and 95th percentiles of simulations, and the dotted lines represent various MICs. Simulations were performed for CSF lactate concentrations of 2 (left), 10 (middle) and 20 (right) mmol/L. ID, infusion dose; LD, loading dose; MD, maintenance dose. This figure appears in colour in the online version of JAC and in black and white in the print version of JAC.

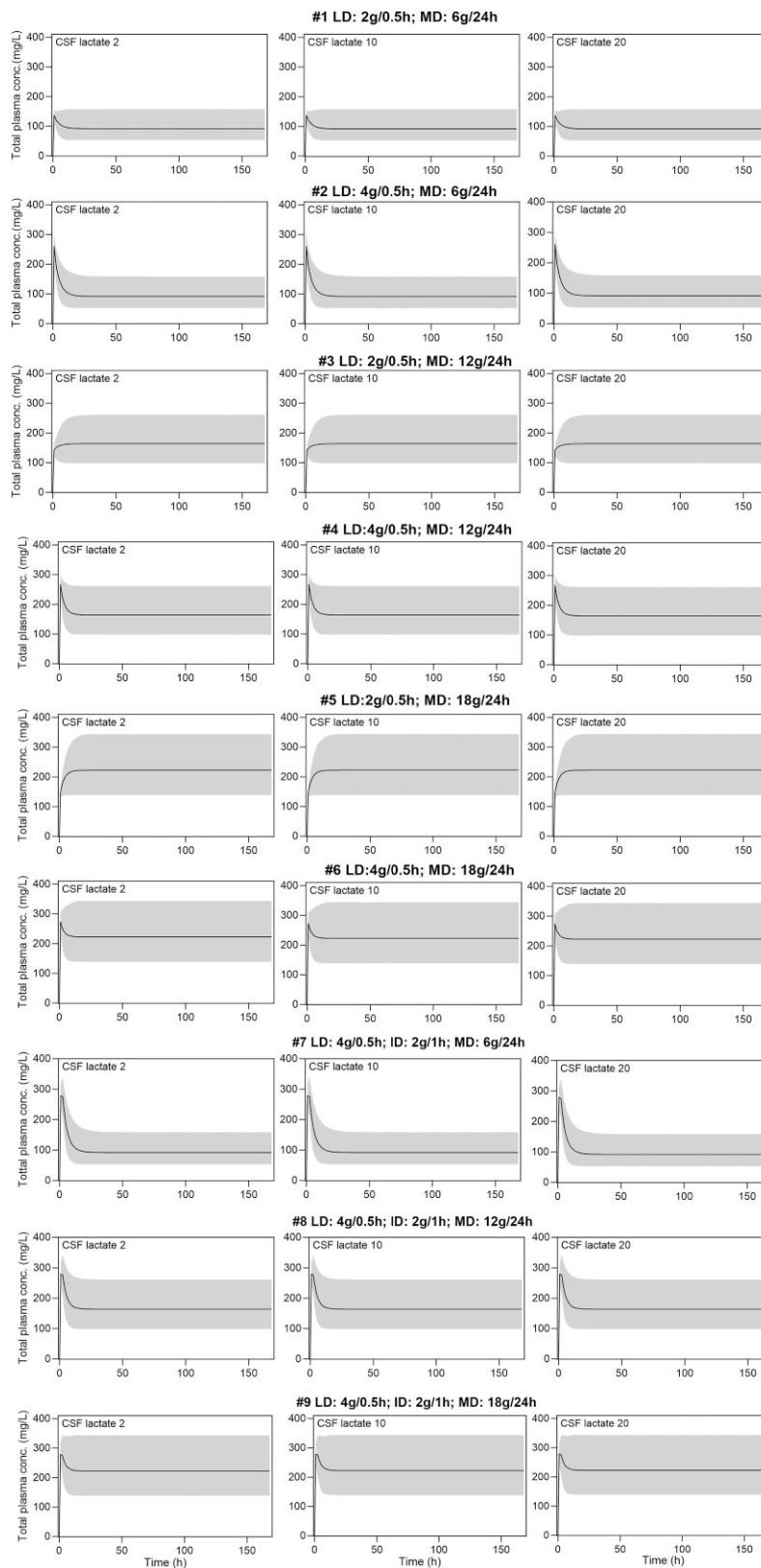

Figure 5. The simulated total plasma concentration-time profiles for temocillin when administered with different dosing regimens. The solid line represents the median of 1000 simulations and the limits of the grey area represent the 5th and 95th percentiles of simulations. Simulations were performed for CSF lactate concentrations of 2 (left), 10 (middle) and 20 (right) mmol/L. ID, infusion dose; LD, loading dose; MD, maintenance dose.

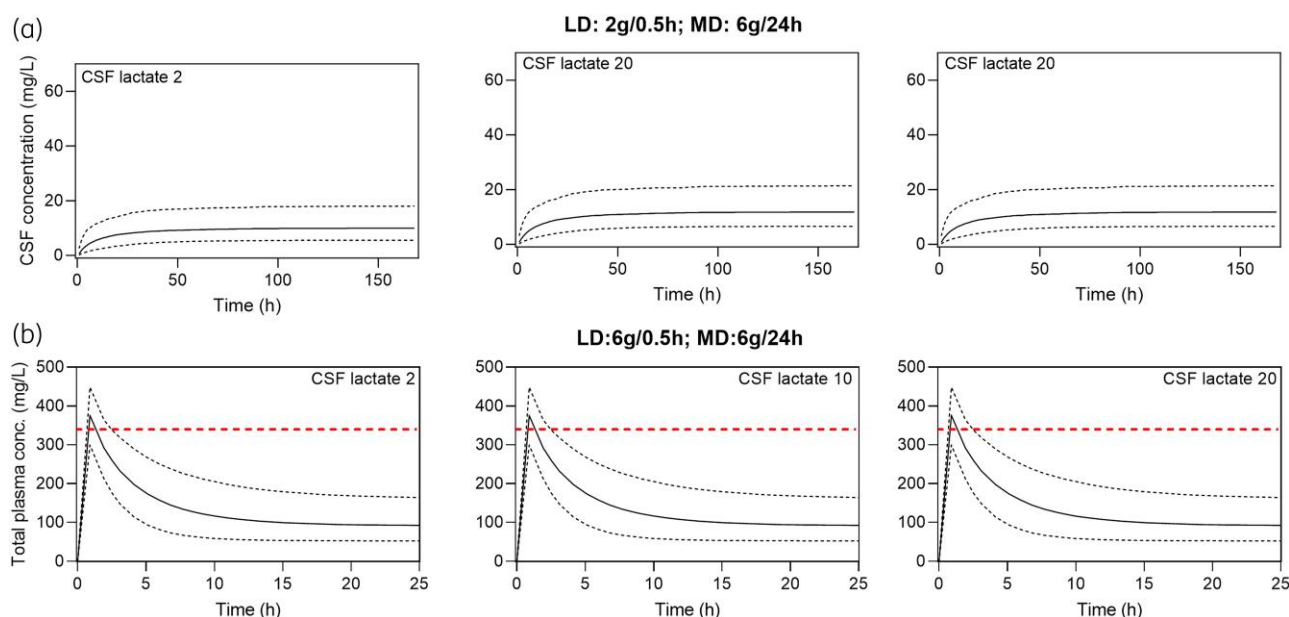

Figure 6. Effects of CSF lactate concentration on unbound CSF and total plasma concentration of temocillin. (a) Simulated CSF concentration-time profiles of temocillin for dosing regimen used in the study with CSF lactate concentrations of 2, 10 and 20 mmol/L; (b) simulated total plasma concentration-time profiles of temocillin for high loading dose of 6 g with CSF lactate concentrations of 2, 10 and 20 mmol/L. The solid black line represents the median of 1000 simulations, and the dashed lines represent the 5th and 95th percentiles of simulations. The red dashed lines indicate total plasma concentration of 350 mg/L. LD, loading dose; MD, maintenance dose. This figure appears in colour in the online version of *JAC* and in black and white in the print version of *JAC*.

haemodialysis patients⁴⁷ using either one-compartment⁴⁶ or two-compartment^{20,40,43,47} models. In the present study, a one-compartment model was found to be the best-performing model, which could be due to limited sampling (1–2 samples) among each dosing 24 h interval, because at least five samples were collected in studies using two-compartment models. Nevertheless, the volume of distribution found in the present study (13.3 L) is comparable to that of the central compartment in most of the studies using one- or two-compartment models in ICU patients (~14.0 L^{20,43,46}). The clearance of unbound temocillin estimated here (8.43 L/h) was higher compared with previous studies in ICU patients (2.45–3.69 L/h),^{20,43} probably related to the fact that creatinine clearance was higher in the patients from this study (125.5 mL/min) than in previous ICU cohorts (40–94 mL/min).^{20,43} Of note, a single study in ICU patients by Layios *et al.*⁴⁰ reported much higher clearance of unbound temocillin (15.2 L/h) and volume of distribution in the central compartment (31 L). These patients had a mean creatinine clearance of 115 mL/min, but values were widely dispersed. This could explain discrepancies in estimated clearance, as renal clearance was used as a covariable. The reason for a higher volume of distribution is less clear, but is possibly related to the fact that patients were treated by intermittent (3×/day) or continuous infusion or that they had higher APACHE II scores.⁴⁰ Lastly, protein and albumin concentrations were not reported in Layios' article.

In our work, no relationship was found between the creatinine clearance and total clearance of temocillin. This is probably due to the narrow range of creatinine clearance in the current patient population (only 1/10 patients below 90 mL/min). No efflux

clearance from the CSF to the blood compartment was considered as patients were undergoing external ventricular drainage, with an estimated clearance from CSF of 0.012 L/h, close to the reported daily CSF drainage volume of 200–300 mL (0.008–0.0125 L/h). Including this process was also not justified mathematically during the model development, in line with previous PK models for other drugs in patients with EVD that considered this clearance as negligible or low compared with the elimination via the drain.^{33,48} The estimated volume of the CSF compartment was 0.17 L, which is close to the 0.15 L of CSF volume in adults.

During covariate analysis, lactate concentration in CSF was the only covariate retained in the final model, which showed a significant effect on temocillin transferring rate constant from the central compartment to CSF. Of note, this covariate, suggested as a surrogate parameter for ventriculitis and meningitis, has already been used in a population pharmacokinetics (popPK) model of vancomycin in a similar patient population, and also found to correlate with the inter-compartment clearance between the central and the CSF compartment.⁴⁹ However, how to justify this covariate clinically needs to be considered.

Monte Carlo simulations showed that exposure to temocillin in the CSF was insufficient to cover bacteria with MICs ≥ 8 mg/L when administered as a continuous infusion of 6 g/24 h after a loading dose of 2 g (i.e. the maximal registered dose) and that much higher maintenance doses should be used for higher MICs if aiming at maintaining the unbound concentration above the MIC during the whole treatment duration. Although limited to dosing regimens that do not expose the patients to peak concentrations >350 mg/L, our simulations propose therapeutic schemes leading to prolonged exposure to high unbound

concentrations in the plasma and the CSF, the safety of which would need to be assessed. Moreover, we do not know at this stage what is the PK/PD target needed to obtain optimal efficacy in CSF. In this context, the few population PK/PD analyses and Monte Carlo simulations performed with other β -lactams suggest suboptimal PTAs when using the highest registered doses, as shown for cefepime, ceftriaxone, ceftazidime or meropenem, if targeting 100% $fT > \text{EUCAST}$ susceptibility breakpoints.^{32,33,50,51} There is thus still room for research in order to define the most clinically relevant CSF PK/PD targets and protocols for dose adjustment before optimizing dosing based on therapeutic drug monitoring for these infections.⁵²

The present data are also subject to some limitations. First, there is a huge inter- and intra-individual variability of the PK parameters estimated in CSF due to the presence of an EVD. Indeed, in shunt CSF, flow rates are variable between and within patients and may affect the amount of CSF produced.⁵³ Second, the number of included patients is small. Moreover, the study was not powered enough to evaluate the treatment's clinical efficacy and to correlate it with PK/PD markers. Our data should also be interpreted cautiously when considering temocillin for other CNS infections.

In conclusion, temocillin shows a CSF penetration comparable to that of other β -lactams. Our simulations suggest that, with the currently approved dosing, temocillin monotherapy may be adequate for the treatment of ventriculitis infections by Enterobacterales with low MICs (≤ 4 mg/L). The dose adjustments proposed based on our simulations would need to be clinically evaluated, particularly with respect to their safety, as only few studies reported the administration of 8–12 g/day in adults patients and healthy volunteers, but encouragingly, they do not mention adverse effects.^{54–56}

Acknowledgements

We would like to thank S. Renard, C. Berghe, M-F. Dujardin and L. Gielens, for their assistance in patient recruitment, and S. Asta for help in HPLC-MS/MS analysis.

Funding

The collection of clinical data, performance of analytical studies, handling and analysis of the results, and preparation of the present paper was part of the PhD thesis of P.N.P., whose work was supported by the Université catholique de Louvain. J.A.R. would like to acknowledge funding from the National Health and Medical Research Council Australia for a Centre of Research Excellence grant (APP2007007) and an Investigator Grant (APP2009736) as well as an Advancing Queensland Clinical Fellowship. No specific funding was set forth to or required by the other participants whose work was supported by the general budget of their clinical or laboratory units by their institutions and considered as part of their normal academic and/or clinical activities.

Transparency declarations

P.N.P. was an employee of the Université catholique de Louvain. X.W., A.V., C.C., P.F. and P.-F.L. are or were employees of the Cliniques universitaires Saint-Luc. F.V.B. is Research Director of the Fonds de la Recherche Scientifique (F.R.S.-FNRS). G.-J.W. is a postdoc and Eumedica, the commercial producer of temocillin, serves as an industrial partner on his BEWARE 2-funded postdoctoral project. The laboratories and/or clinical

units of F.V.B. and P.-F.L. have received research supporting grants and/or honoraria from various industries for research work and/or presentations unrelated to the topic of the present paper. All other authors have no potential conflicts of interest to declare.

Supplementary data

Figures S1 to S4, Tables S1 to S4, Supplementary methods 1 and 2, and Supplementary material 1 are available as Supplementary data at JAC Online.

References

- 1 Changa AR, Czeisler BM, Lord AS. Management of elevated intracranial pressure: a review. *Curr Neurol Neurosci Rep* 2019; **19**: 99. <https://doi.org/10.1007/s11910-019-1010-3>
- 2 Schizodimos T, Soulountsi V, Iasonidou C et al. An overview of management of intracranial hypertension in the intensive care unit. *J Anesth* 2020; **34**: 741–57. <https://doi.org/10.1007/s00540-020-02795-7>
- 3 Martin RM, Zimmermann LL, Huynh M et al. Diagnostic approach to health care- and device-associated central nervous system infections. *J Clin Microbiol* 2018; **56**: e00861-18. <https://doi.org/10.1128/JCM.00861-18>
- 4 Ramasy Razafindratovo RM, Migliavaca CB, Chevret S et al. Internal ventricular cerebrospinal fluid shunt for adult hydrocephalus: a systematic review and meta-analysis of the infection rate. *Neurosurgery* 2022; **92**: 894–904. <https://doi.org/10.1227/neu.0000000000002301>
- 5 Ramanan M, Lipman J, Shorr A et al. A meta-analysis of ventriculostomy-associated cerebrospinal fluid infections. *BMC Infect Dis* 2015; **15**: 3. <https://doi.org/10.1186/s12879-014-0712-z>
- 6 Karvouniaris M, Brotis A, Tsiakos K et al. Current perspectives on the diagnosis and management of healthcare-associated ventriculitis and meningitis. *Infect Drug Resist* 2022; **15**: 697–721. <https://doi.org/10.2147/IDR.S326456>
- 7 Srihawan C, Castelblanco RL, Salazar L et al. Clinical characteristics and predictors of adverse outcome in adult and pediatric patients with healthcare-associated ventriculitis and meningitis. *Open Forum Infect Dis* 2016; **3**: ofw077. <https://doi.org/10.1093/ofid/ofw077>
- 8 Pelegrin I, Lora-Tamayo J, Gomez-Junyent J et al. Management of ventriculoperitoneal shunt infections in adults: analysis of risk factors associated with treatment failure. *Clin Infect Dis* 2017; **64**: 989–97. <https://doi.org/10.1093/cid/cix005>
- 9 Lutsar I, McCracken GHJ, Friedland IR. Antibiotic pharmacodynamics in cerebrospinal fluid. *Clin Infect Dis* 1998; **27**: 1117–27. <https://doi.org/10.1086/515003>
- 10 Tunkel AR, Hasbun R, Bhimraj A et al. 2017 Infectious Diseases Society of America's clinical practice guidelines for healthcare-associated ventriculitis and meningitis. *Clin Infect Dis* 2017; **64**: e34–65. <https://doi.org/10.1093/cid/ciw861>
- 11 Livermore DM, Tulkens PM. Temocillin revived. *J Antimicrob Chemother* 2009; **63**: 243–5. <https://doi.org/10.1093/jac/dkn511>
- 12 Livermore DM, Hope R, Fagan EJ et al. Activity of temocillin against prevalent ESBL- and AmpC-producing Enterobacteriaceae from south-east England. *J Antimicrob Chemother* 2006; **57**: 1012–4. <https://doi.org/10.1093/jac/dkl043>
- 13 Balakrishnan I, Awad-El-Kariem FM, Aali A et al. Temocillin use in England: clinical and microbiological efficacies in infections caused by extended-spectrum and/or derepressed AmpC beta-lactamase-producing Enterobacteriaceae. *J Antimicrob Chemother* 2011; **66**: 2628–31. <https://doi.org/10.1093/jac/dkr317>

- 14** Mittermayer HW. Influence of temocillin on human bowel flora. *Drugs* 1985; **29** Suppl 5: 43–8. <https://doi.org/10.2165/00003495-198500295-00010>
- 15** Alexandre K, Fantin B. Pharmacokinetics and pharmacodynamics of temocillin. *Clin Pharmacokinet* 2018; **57**: 287–96. <https://doi.org/10.1007/s40262-017-0584-7>
- 16** Bruckner O, Trautmann M, Borner K. A study of the penetration of temocillin in the cerebrospinal fluid. *Drugs* 1985; **29** Suppl 5: 162–6. <https://doi.org/10.2165/00003495-198500295-00033>
- 17** EUCAST. Breakpoints for temocillin. 2020. https://www.eucast.org/fileadmin/src/media/PDFs/EUCAST_files/Breakpoint_tables/Addenda/Addendum_Temocillin_breakpoints_and_AST_2020.pdf
- 18** Craig WA. Basic pharmacodynamics of antibacterials with clinical applications to the use of beta-lactams, glycopeptides, and linezolid. *Infect Dis Clin North Am* 2003; **17**: 479–501. [https://doi.org/10.1016/S0891-5520\(03\)00065-5](https://doi.org/10.1016/S0891-5520(03)00065-5)
- 19** Wong G, Briscoe S, McWhinney B *et al.* Therapeutic drug monitoring of beta-lactam antibiotics in the critically ill: direct measurement of unbound drug concentrations to achieve appropriate drug exposures. *J Antimicrob Chemother* 2018; **73**: 3087–94. <https://doi.org/10.1093/jac/dky314>
- 20** Laterre PF, Wittebole X, Van de Velde S *et al.* Temocillin (6g daily) in critically ill patients: continuous infusion versus three times daily administration. *J Antimicrob Chemother* 2015; **70**: 891–8. <https://doi.org/10.1093/jac/dku465>
- 21** Ngougni Pokem P, Matzneller P, Vervaeke S *et al.* Binding of temocillin to plasma proteins in vitro and in vivo: the importance of plasma protein levels in different populations and of co-medications. *J Antimicrob Chemother* 2022; **77**: 2742–53. <https://doi.org/10.1093/jac/dkac286>
- 22** Matzneller P, Ngougni Pokem P, Capron A *et al.* Single-dose pharmacokinetics of temocillin in plasma and soft tissues of healthy volunteers after intravenous and subcutaneous administration: a randomized cross-over microdialysis trial. *J Antimicrob Chemother* 2020; **75**: 2650–6. <https://doi.org/10.1093/jac/dkaa176>
- 23** U.S. Department of Health and Human Services. Guidance for industry: bioanalytical method validation. 2018. <https://www.fda.gov/files/drugs/published/Bioanalytical-Method-Validation-Guidance-for-Industry.pdf>
- 24** Weichselbaum TE. An accurate and rapid method for the determination of proteins in small amounts of blood serum and plasma. *Am J Clin Pathol* 1946; **10**: 40–9. https://doi.org/10.1093/ajcp/16.3_ts.40
- 25** Doumas BT, Watson WA, Biggs HG. Albumin standards and the measurement of serum albumin with bromocresol green. *Clin Chim Acta* 1971; **31**: 87–96. [https://doi.org/10.1016/0009-8981\(71\)90365-2](https://doi.org/10.1016/0009-8981(71)90365-2)
- 26** Pai MP, Russo A, Novelli A *et al.* Simplified equations using two concentrations to calculate area under the curve for antimicrobials with concentration-dependent pharmacodynamics: daptomycin as a motivating example. *Antimicrob Agents Chemother* 2014; **58**: 3162–7. <https://doi.org/10.1128/AAC.02355-14>
- 27** Nau R, Zysk G, Thiel A *et al.* Pharmacokinetic quantification of the exchange of drugs between blood and cerebrospinal fluid in man. *Eur J Clin Pharmacol* 1993; **45**: 469–75. <https://doi.org/10.1007/BF00315520>
- 28** Model for individual covariates. Monolix; 2023. <https://monolix.lixoft.com/statistical-model/individual-model/covariate/>
- 29** Nau R, Sorgel F, Eiffert H. Penetration of drugs through the blood-cerebrospinal fluid/blood-brain barrier for treatment of central nervous system infections. *Clin Microbiol Rev* 2010; **23**: 858–83. <https://doi.org/10.1128/CMR.00007-10>
- 30** Richards ML, Prince RA, Kenaley KA *et al.* Antimicrobial penetration into cerebrospinal fluid. *Drug Intell Clin Pharm* 1981; **15**: 341–68. <https://doi.org/10.1177/106002808101500505>
- 31** Bakken JS, Bruun JN, Gaustad P *et al.* Penetration of amoxicillin and potassium clavulanate into the cerebrospinal fluid of patients with inflamed meninges. *Antimicrob Agents Chemother* 1986; **30**: 481–4. <https://doi.org/10.1128/AAC.30.3.481>
- 32** Lodise TPJ, Rhoney DH, Tam VH *et al.* Pharmacodynamic profiling of cefepime in plasma and cerebrospinal fluid of hospitalized patients with external ventriculostomies. *Diagn Microbiol Infect Dis* 2006; **54**: 223–30. <https://doi.org/10.1016/j.diagmicrobio.2005.09.007>
- 33** Sime FB, Lassig-Smith M, Starr T *et al.* Cerebrospinal fluid penetration of ceftolozane-tazobactam in critically ill patients with an indwelling external ventricular drain. *Antimicrob Agents Chemother* 2020; **65**: e01698-20. <https://doi.org/10.1128/AAC.01698-20>
- 34** Dahyot-Fizelier C, Frasca D, Gregoire N *et al.* Microdialysis study of cefotaxime cerebral distribution in patients with acute brain injury. *Antimicrob Agents Chemother* 2013; **57**: 2738–42. <https://doi.org/10.1128/AAC.02570-12>
- 35** Poepl W, Zeitlinger M, Donath O *et al.* Penetration of doripenem in human brain: an observational microdialysis study in patients with acute brain injury. *Int J Antimicrob Agents* 2012; **39**: 343–5. <https://doi.org/10.1016/j.ijantimicag.2011.11.019>
- 36** Blassmann U, Roehr AC, Frey OR *et al.* Cerebrospinal fluid penetration of meropenem in neurocritical care patients with proven or suspected ventriculitis: a prospective observational study. *Crit Care* 2016; **20**: 343. <https://doi.org/10.1186/s13054-016-1523-y>
- 37** Nau R, Lassek C, Kinzig-Schippers M *et al.* Disposition and elimination of meropenem in cerebrospinal fluid of hydrocephalic patients with external ventriculostomy. *Antimicrob Agents Chemother* 1998; **42**: 2012–6. <https://doi.org/10.1128/AAC.42.8.2012>
- 38** Drwiega EN, Rodvold KA. Penetration of antibacterial agents into pulmonary epithelial lining fluid: an update. *Clin Pharmacokinet* 2022; **61**: 17–46. <https://doi.org/10.1007/s40262-021-01061-7>
- 39** Wise R. Methods for evaluating the penetration of beta-lactam antibiotics into tissues. *Rev Infect Dis* 1986; **8** Suppl 3: S325–32. https://doi.org/10.1093/clinids/8.Supplement_3.S325
- 40** Layios N, Visee C, Mistretta V *et al.* Modelled target attainment after temocillin treatment in severe pneumonia: systemic and epithelial lining fluid pharmacokinetics of continuous versus intermittent infusions. *Antimicrob Agents Chemother* 2022; **66**: e0205221. <https://doi.org/10.1128/aac.02052-21>
- 41** Brown RM, Wise R, Andrews JM. Temocillin, in-vitro activity and the pharmacokinetics and tissue penetration in healthy volunteers. *J Antimicrob Chemother* 1982; **10**: 295–302. <https://doi.org/10.1093/jac/10.4.295>
- 42** Wise R, Donovan IA, Drumm J *et al.* The intraperitoneal penetration of temocillin. *J Antimicrob Chemother* 1983; **12**: 93–6. <https://doi.org/10.1093/jac/12.1.93>
- 43** Ngougni Pokem P, Wittebole X, Collienne C *et al.* Population pharmacokinetics of temocillin administered by continuous infusion in patients with septic shock associated with intra-abdominal infection and ascitic fluid effusion. *Antibiotics (Basel)* 2022; **11**: 898. <https://doi.org/10.3390/antibiotics11070898>
- 44** Nau R, Kinzig-Schippers M, Sorgel F *et al.* Kinetics of piperacillin and tazobactam in ventricular cerebrospinal fluid of hydrocephalic patients. *Antimicrob Agents Chemother* 1997; **41**: 987–91. <https://doi.org/10.1128/AAC.41.5.987>
- 45** Quagliarello VJ, Long WJ, Scheld WM. Morphologic alterations of the blood-brain barrier with experimental meningitis in the rat. Temporal sequence and role of encapsulation. *J Clin Invest* 1986; **77**: 1084–95. <https://doi.org/10.1172/JCI112407>
- 46** De Jongh R, Hens R, Basma V *et al.* Continuous versus intermittent infusion of temocillin, a directed spectrum penicillin for intensive care

patients with nosocomial pneumonia: stability, compatibility, population pharmacokinetic studies and breakpoint selection. *J Antimicrob Chemother* 2008; **61**: 382–8. <https://doi.org/10.1093/jac/dkm467>

47 Miranda Bastos AC, Vandecasteele SJ, Spinewine A et al. Temocillin dosing in haemodialysis patients based on population pharmacokinetics of total and unbound concentrations and Monte Carlo simulations. *J Antimicrob Chemother* 2018; **73**: 1630–8. <https://doi.org/10.1093/jac/dky078>

48 Chauzy A, Nadji A, Combes JC et al. Cerebrospinal fluid pharmacokinetics of ceftaroline in neurosurgical patients with an external ventricular drain. *J Antimicrob Chemother* 2019; **74**: 675–81. <https://doi.org/10.1093/jac/dky489>

49 Jalusic KO, Hempel G, Arnemann PH et al. Population pharmacokinetics of vancomycin in patients with external ventricular drain-associated ventriculitis. *Br J Clin Pharmacol* 2021; **87**: 2502–10. <https://doi.org/10.1111/bcp.14657>

50 Lodise TP, Nau R, Kinzig M et al. Pharmacodynamics of ceftazidime and meropenem in cerebrospinal fluid: results of population pharmacokinetic modelling and Monte Carlo simulation. *J Antimicrob Chemother* 2007; **60**: 1038–44. <https://doi.org/10.1093/jac/dkm325>

51 Lodise TPJ, Nau R, Kinzig M et al. Comparison of the probability of target attainment between ceftriaxone and cefepime in the cerebrospinal fluid and serum against *Streptococcus pneumoniae*. *Diagn Microbiol Infect Dis* 2007; **58**: 445–52. <https://doi.org/10.1016/j.diagmicrobio.2007.03.015>

52 Arkell P, Wilson R, Watkins K et al. Application of therapeutic drug monitoring to the treatment of bacterial central nervous system infection: a scoping review. *J Antimicrob Chemother* 2022; **77**: 3408–13. <https://doi.org/10.1093/jac/dkac332>

53 Kadowaki C, Hara M, Numoto M et al. CSF shunt physics: factors influencing inshunt CSF flow. *Childs Nerv Syst* 1995; **11**: 203–6. <https://doi.org/10.1007/BF00277654>

54 Michelon H, Bouabdallah-Perrin L, Singh S et al. Utilisation de la témocilline: étude de cohorte. *Méd Mal Infect* 2020; **50**: S50–1. <https://doi.org/10.1016/j.medmal.2020.06.094>

55 Nunn B, Baird A, Chamberlain PD. Effect of temocillin and moxalactam on platelet responsiveness and bleeding time in normal volunteers. *Antimicrob Agents Chemother* 1985; **27**: 858–62. <https://doi.org/10.1128/AAC.27.5.858>

56 Amaddeo A, Poli F, Barbi E et al. Temocillin: time to rediscover it? *J Cyst Fibros* 2010; **9**: S121. [https://doi.org/10.1016/S1569-1993\(10\)60462-6](https://doi.org/10.1016/S1569-1993(10)60462-6)